

## IMPORTANT NOTICE

**This document must ONLY be used for an approved ringfence case**

This document is ringfenced due to existing Regulatory Authorisations that require it to remain in service.

All documents not in a ringfence are archived following the transition from separate management systems for Woodside and BHPP to a single harmonised [Our Woodside Management System](#) (Our WMS) on 31<sup>st</sup> March 2025.

If you are not sure if you should be working in a ringfence, consult the Process Owner for this document or the [WMS Team](#).

### CONTROLLED DOCUMENT

Terminal Handbook Pluto



Controlled Ref No: **XA7500MW0001**

Revision: **23**

Name		Signature	Date
<b>Prepared by:</b>	Matthew Ashworth		
<i>Recommender – Person creating/editing the document</i>			
<b>Approved by:</b>	Ian Polglase		
<i>Decider – Person validating document content</i>			
<b>Custodian:</b>	Glenn Attrill		
<i>Performer – Person managing document lifecycle</i>			
<b>Concurrence:</b> <i>Agreer – Agreement that must be obtained if an item is prepared external to, but impacts, a department or division. If concurrence is required, it must be noted within the body of the item.</i>			

Revision History				
Revision	Description	Date	Prepared by	Approved by
20	Added note in Section 5.1.2. Made minor content changes to Section 6.9. Made minor content updates.	04/12/2024	Geoff Read and Lauren Reeve	Ian Polglase
21	Made minor changes to Sections 5.1.2 and 5.8.10.	24/01/2025	Matthew Ashworth	Ian Polglase
22	Made minor changes to Section 5.5, APPENDIX K, and APPENDIX P	19/05/2025	Matthew Ashworth	Ian Polglase
23	Minor amendments to Section 9.2 and Appendix K	07/10/2025	Matthew Ashworth	Ian Polglase

**This document supersedes (if applicable):**

This document is protected by copyright. No part of this document may be reproduced, adapted, transmitted, or stored in any form by any process (electronic or otherwise) without the specific written consent of Woodside. All rights are reserved.

Controlled Ref No: XA7500MW0001

Revision: 23

Native file No: 5221942

Page 1 of 73

Uncontrolled when printed. Refer to electronic version for most up to date information.

<b>Information Security Sensitivity Classification</b> <i>Check one box only</i>	<input checked="" type="checkbox"/> <b>Public</b> <i>(Approved for public dissemination)</i>	<input type="checkbox"/> <b>Confidential</b> <i>(Shared with named individuals and groups)</i>
	<input type="checkbox"/> <b>Internal</b> <i>(Shared with all Woodside personnel)</i>	<input type="checkbox"/> <b>Most Confidential</b> <i>(Shared with named individuals only)</i>
<b>Prepared by:</b>	<input checked="" type="checkbox"/> WEL	<input type="checkbox"/> for WEL – PO/Contract No:

<b>Operations/Projects Use Only</b>	
Operating Facility:	Pluto Terminal
Key TAG Nos:	

<b>Document Distribution</b>		
<b>Full Name/External Organisation Name (if applicable)</b> <i>(Show Username (WOPID) to differentiate between persons with identical names).</i>	<b>Hard Copy</b>	<b>Electronic Notification</b>
Document Control	<input type="checkbox"/>	<input checked="" type="checkbox"/>
Pluto Asset Manager <a href="mailto:kate.bardill@woodside.com">kate.bardill@woodside.com</a>	<input type="checkbox"/>	<input checked="" type="checkbox"/>
Pluto OIM <a href="mailto:PLP_OIM@woodside.com.au">PLP_OIM@woodside.com.au</a>	<input type="checkbox"/>	<input checked="" type="checkbox"/>
Logistics Marine	<input type="checkbox"/>	<input checked="" type="checkbox"/>
Port Operations Marine Pilots <a href="mailto:??Pilots">??Pilots</a>	<input type="checkbox"/>	<input checked="" type="checkbox"/>
Port Operations Superintendent <a href="mailto:PortOpsSuper@woodside.com.au">PortOpsSuper@woodside.com.au</a>	<input type="checkbox"/>	<input checked="" type="checkbox"/>
Shipping Office <a href="mailto:ShippingOfficePlant@woodside.com.au">ShippingOfficePlant@woodside.com.au</a>	<input type="checkbox"/>	<input checked="" type="checkbox"/>
Gulf Agency Company (Australia) Pty Ltd <a href="mailto:shipping.dampier@gac.com">shipping.dampier@gac.com</a>	<input type="checkbox"/>	<input checked="" type="checkbox"/>
Wilhelmsen Port Services <a href="mailto:wps.dampier@wilhelmsen.com">wps.dampier@wilhelmsen.com</a>	<input type="checkbox"/>	<input checked="" type="checkbox"/>
Inchcape Shipping Services Pty Ltd <a href="mailto:dampier@ISS-shipping.com">dampier@ISS-shipping.com</a>	<input type="checkbox"/>	<input checked="" type="checkbox"/>
Wave Shipping <a href="mailto:ops@wave-shipping.com.au">ops@wave-shipping.com.au</a>	<input type="checkbox"/>	<input checked="" type="checkbox"/>
Harbour/Deputy Master <a href="mailto:hm.dhm@pilbaraports.com.au">hm.dhm@pilbaraports.com.au</a>	<input type="checkbox"/>	<input checked="" type="checkbox"/>
Phil Park (Manager Technical & Shipping) <a href="mailto:phil.park@woodside.com">phil.park@woodside.com</a>	<input type="checkbox"/>	<input checked="" type="checkbox"/>
Kylie Vlasschaert (General Manager Ops Pacific Seaborne) <a href="mailto:kylie.vlasschaert@woodside.com">kylie.vlasschaert@woodside.com</a>	<input type="checkbox"/>	<input checked="" type="checkbox"/>
Marine Assurance <a href="mailto:MarineAssurance@woodside.com.au">MarineAssurance@woodside.com.au</a>	<input type="checkbox"/>	<input checked="" type="checkbox"/>
Clinton Chambers (Team Lead Offtake) <a href="mailto:clinton.chambers@woodside.com">clinton.chambers@woodside.com</a>	<input type="checkbox"/>	<input checked="" type="checkbox"/>

## PREFACE

This document is intended to acquaint Owners, Charterers, and Masters of Vessels with the general conditions, terminal facilities, and available services at the Pluto Terminal.

It does not replace or modify official publications covering the waters, hazards, areas, or subjects to which it pertains, nor is it intended for such purposes. All operations are subject to terminal procedures and port regulations.

While the information herein is believed to be correct at the time of printing, the Terminal Operator makes no guarantee and assumes no responsibilities regarding it or any information that can appear in supplemental publications.

To the extent this document contains any forward-looking statements, these are subject to risk factors associated with the oil and gas business. The expectations reflected in these statements are reasonable, but they can be affected by a variety of variables and changes in underlying assumptions that could cause actual results or trends to differ materially, including, but not limited to:

- environmental risks
- physical risks
- legislative
- fiscal
- regulatory developments
- approvals.

## TABLE OF CONTENTS

<b>PREFACE .....</b>	<b>3</b>
<b>1. PORT OF DAMPIER.....</b>	<b>9</b>
1.1 Location.....	9
1.2 Administration .....	9
1.3 Environment.....	9
1.3.1 Quarantine.....	9
1.4 Charts and Publications.....	10
1.5 General Weather Information .....	10
1.5.1 Winds.....	10
1.5.2 Cyclones.....	10
1.6 Tides and Currents .....	10
1.6.1 Tides.....	10
1.6.2 Currents.....	11
1.7 Anchorages.....	11
1.8 Prohibited Areas .....	11
1.9 Gas Trunkline.....	11
<b>2. WOODSIDE FACILITIES IN PORT OF DAMPIER .....</b>	<b>11</b>
2.1 Pluto Terminal.....	11
2.2 Withnell Bay Terminal.....	11
2.3 Loading Facilities .....	12
2.4 King Bay Supply Facility .....	12
2.5 Declared Depths .....	12
2.6 Woodside and Pluto Channels .....	12
2.6.1 Sea Buoy.....	12
2.6.2 Rio Tinto Channel .....	12
2.6.3 Pilot Boarding Grounds.....	12
2.6.5 Woodside Alternate Route.....	13
2.6.6 Swing Basin Manoeuvring Area.....	13
2.6.7 Berth Pockets.....	13
2.7 Jetty Facilities .....	13
2.8 Mooring Load and Environmental Monitoring System (MEMS).....	14
2.8.1 Mooring Load Monitoring .....	14
2.8.2 Environmental Monitoring .....	14
2.9 Jetty Rules .....	14
2.9.1 Access.....	14
2.9.2 Stores .....	16
2.9.3 Engine Repairs.....	16
2.9.4 Fresh Water.....	16
2.9.5 Bunkers .....	16
2.9.6 Liquid Nitrogen .....	16
2.9.7 Gangway .....	16
2.9.8 Lifeboat Drills .....	17
2.9.9 Tanker Emergency Equipment Testing .....	17
2.9.10 Australian Government Requirements .....	17

2.9.11	Ballast Water Discharge Management.....	17
2.9.12	Discharge of Open Loop Exhaust Gas Cleaning Systems .....	17
<b>3.</b>	<b>COMMUNICATIONS .....</b>	<b>17</b>
3.1	Communications Plan Dampier .....	18
3.1.1	Pre-Arrival Communication .....	18
3.1.2	Tanker Pre-Arrival Messages .....	18
3.1.3	Arrival Port of Dampier Limits .....	19
3.2	Pluto Terminal Pre-Arrival Questionnaire (LNG Carriers).....	19
3.2.1	Sequence of Messages .....	20
3.3	Pluto Terminal Pre-Arrival Questionnaire (Condensate Tankers).....	21
3.4	Port Health .....	21
3.4.1	Quarantine Anchorage.....	21
3.5	Weather Reports.....	21
3.6	Communication Terminology.....	21
<b>4.</b>	<b>SHIP COMPATIBILITY AND ASSURANCE .....</b>	<b>21</b>
4.1	Sanctions Assessment Procedure .....	22
<b>5.</b>	<b>BERTHING ARRANGEMENTS .....</b>	<b>22</b>
5.1	Pilotage .....	22
5.1.1	Pilotage Requirements.....	22
5.1.2	Pilot Boarding Requirements .....	22
5.2	Terminal Representative.....	24
5.3	Channel Transit.....	24
5.3.1	PPU Berthing Aids .....	24
5.3.2	Transit Criteria and Weather Limitations .....	24
5.3.3	Inward Transits.....	25
5.3.4	Outward Transits.....	25
5.4	Transit Restrictions for Vessel (LNG/Condensate) .....	25
5.5	Transit Speeds.....	25
5.6	Tanker Drafts .....	26
5.6.1	Inwards Draughts – LNG Tankers .....	26
5.6.2	Minimum UKC Alongside .....	26
5.6.3	Outwards Drafts .....	26
5.7	Towage Services .....	26
5.7.1	Tug Fleet .....	26
5.7.2	Allocation of Tugs.....	26
5.7.3	Tug Requirements.....	27
5.7.4	Tugs on Station .....	27
5.7.5	Securing of Tugs .....	27
5.7.6	Standby Tug Duties.....	27
5.8	Mooring Requirements .....	27
5.8.1	Mooring Integrity .....	27
5.8.2	Mooring Tensions.....	28
5.8.3	Condensate Tanker Minimum Requirements.....	28
5.8.4	Condensate Tankers’ Mooring Requirements.....	28
5.8.5	Mooring Lines.....	28

5.8.6	Running of Mooring Lines .....	29
5.8.7	Excessive Mooring Line Tensions .....	29
5.8.8	Mooring Line Failure .....	30
5.8.9	Limiting Conditions Alongside.....	30
5.8.10	Early Departure Guidance For Membrane LNG Tankers: .....	30
5.8.11	Loading Arm Wind Limitations .....	30
5.8.12	Electrical Storms .....	30
<b>6.</b>	<b>SAFETY PRECAUTIONS.....</b>	<b>31</b>
6.1	Cargo Handling Philosophy .....	31
6.1.1	Loss of Containment .....	31
6.2	Medical Advice .....	31
6.3	Ship/Shore Communications .....	31
6.3.1	VHF/UHF Radio Link .....	31
6.4	Emergency Documents .....	31
6.4.1	Ship/Shore Safety Check List .....	32
6.5	Vessel Readiness .....	32
6.5.1	Main Engine Readiness .....	32
6.5.2	Minor Shipboard Repairs .....	32
6.6	Fire Prevention.....	32
6.7	Fire Fighting Equipment.....	33
6.7.1	Tanker .....	33
6.7.2	Terminal .....	33
6.7.3	Environmental Pollution .....	33
6.7.4	Avoidance of Pollution .....	33
6.8	Manifold Access.....	34
6.9	Accommodation Access .....	34
<b>7.</b>	<b>SERVICES .....</b>	<b>35</b>
7.1	Fuel .....	35
7.2	Refuse.....	35
7.3	Fresh Water .....	35
7.4	Stores and Provisions.....	35
7.5	Repairs.....	35
7.6	Customs.....	35
7.7	Police .....	35
7.8	Security .....	35
7.9	Air Communications.....	35
7.10	Medical Assistance .....	35
<b>7.1</b>	<b>GENERAL RESPONSIBILITIES.....</b>	<b>36</b>
7.1.1	Pilotage .....	36
7.1.2	Terminal Representative/Loadmaster .....	36
<b>8.</b>	<b>CONTACTS .....</b>	<b>36</b>
8.1	Woodside Contacts.....	36
8.2	Pilbara Ports Operations.....	37
8.3	Shipping Agencies .....	37
<b>9.</b>	<b>LNG LOADING FACILITIES .....</b>	<b>38</b>

9.1	LNG Carrier Particulars .....	38
9.2	LNG Communication System .....	38
9.3	LNG Venting .....	39
9.4	LNG Tanker ESD System.....	39
9.5	Pre-Loading Operations.....	39
9.5.1	Fitting of Gangway .....	39
9.5.2	Pre-Loading Meeting.....	39
9.6	Configuration and Limits of Loading Arms .....	39
9.6.1	QC/DC .....	39
9.6.2	Configuration .....	40
9.6.3	Water Spray System .....	41
9.6.4	Measurement of Cargo Heel.....	41
9.6.5	Testing the ESD System.....	41
9.7	Cargo Handling .....	42
9.7.1	Normal Loading.....	42
9.7.2	Vessel Exclusion Zone.....	42
9.7.3	Inerted Condition .....	42
9.7.4	Cooldown and Gassing Up .....	42
9.7.5	Loading and Topping Off .....	43
9.7.6	Prevention of Free Flow of Liquid .....	45
9.7.7	Cargo Ramp-Up and Ramp-Down .....	45
9.8	Draining and Inerting of Loading Arms.....	45
9.9	Completion of Operations.....	45
9.9.1	Disconnection of Loading Arms .....	45
9.10	Final Measurement of Cargo .....	45
9.11	Documentation .....	46
9.12	Removal of Gangway .....	46
9.13	Main Engine Preparation for Sailing.....	46
<b>10.</b>	<b>CONDENSATE LOADING FACILITIES .....</b>	<b>46</b>
10.1	Condition of Condensate Tankers.....	46
10.2	Loading Rates.....	47
10.3	Shore Tank Capacity .....	47
10.4	Loading Arms.....	47
10.4.1	Loading Arm Limits .....	47
10.4.2	Connection of Loading Arms .....	47
10.5	QC/DC.....	48
10.6	Emergency Shut Down System.....	48
10.7	Cargo Measurement .....	48
	<b>REFERENCES.....</b>	<b>49</b>
	<b>DEFINITIONS.....</b>	<b>49</b>
	<b>ABBREVIATIONS.....</b>	<b>50</b>
	<b>APPENDIX A RECOMMENDED APPROACHES TO THE PORT OF DAMPIER.....</b>	<b>53</b>
	<b>APPENDIX B PLUTO TERMINAL.....</b>	<b>54</b>
B.1	Pluto Terminal Approaches .....	54

B.2	Pluto Terminal Exclusion Zone.....	55
<b>APPENDIX C</b>	<b>JETTY LOADING PLATFORM – GANGWAY ARRANGEMENT.....</b>	<b>56</b>
<b>APPENDIX D</b>	<b>JETTY LOADING PLATFORM – GANGWAY ARRANGEMENT (ELEVATION) .....</b>	<b>57</b>
<b>APPENDIX E</b>	<b>JETTY LADDER ARRANGEMENT ON GANGWAY.....</b>	<b>58</b>
<b>APPENDIX F</b>	<b>LNG LOADING ARM WORKING RANGE (ELEVATION) .....</b>	<b>59</b>
<b>APPENDIX G</b>	<b>LNG LOADING ARM WORKING RANGE (PLAN) .....</b>	<b>60</b>
<b>APPENDIX H</b>	<b>CONDENSATE LOADING ARM WORKING RANGE (ELEVATION) .....</b>	<b>61</b>
<b>APPENDIX I</b>	<b>CONDENSATE ARM WORKING RANGE (PLAN) .....</b>	<b>62</b>
<b>APPENDIX J</b>	<b>MOORING PROCEDURE .....</b>	<b>63</b>
<b>APPENDIX K</b>	<b>PLUTO TRANSIT AND TUG USE CRITERIA TABLE.....</b>	<b>64</b>
<b>APPENDIX L</b>	<b>PLUTO TERMINAL SPOOL PIECE (SHORT DISTANCE PIECE).....</b>	<b>65</b>
<b>APPENDIX M</b>	<b>PLUTO TERMINAL JETTY .....</b>	<b>66</b>
<b>APPENDIX N</b>	<b>SECURITY ARRANGEMENTS FOR SHIP’S CREW .....</b>	<b>67</b>
<b>APPENDIX O</b>	<b>REQUIRED BOARDING ARRANGEMENTS FOR PILOT.....</b>	<b>69</b>
<b>APPENDIX P</b>	<b>PLUTO TERMINAL PRE-ARRIVAL QUESTIONNAIRE (LNG TANKER) .....</b>	<b>70</b>
<b>APPENDIX Q</b>	<b>PLUTO TERMINAL PRE-ARRIVAL QUESTIONNAIRE (CONDENSATE TANKER) .....</b>	<b>71</b>
<b>APPENDIX R</b>	<b>SANCTIONS ASSESSMENT PROCEDURE.....</b>	<b>72</b>
	Sanctions Assessment Procedure.....	72
	Sanctions Declaration .....	73

# 1. PORT OF DAMPIER

## 1.1 Location

The port is located on the northwest coast of Australia within the Dampier Archipelago. Legendre Island is positioned at 20°21'S 116°51'E and forms the north-eastern extremity of the Archipelago and Rosemary Island in position 20°28'S 116°37'E forms the north-western extremity. The expanse of water within these bounds is named Mermaid Sound. A recommended approach track is indicated for the Port of Dampier in APPENDIX A.

## 1.2 Administration

The Dampier Port Authority, through the office of the Harbour Master, administers the port. The [Western Australian \(WA\) Port Authorities Act 1999](#) and the [WA Port Authorities Regulations 2001](#) govern conduct within the port.

The Port of Dampier services five major export operations:

1. Woodside Energy exporting North West Shelf Joint Venture (NWSJV) liquefied natural gas (LNG), liquefied petroleum gas (LPG), and condensate through the Withnell Bay Terminal.
2. Woodside Energy exporting Pluto LNG and condensate through the Pluto Terminal.
3. Rio Tinto Iron Ore Pty Ltd exporting iron ore through their Parker Point and East Intercourse Island terminals.
4. Dampier Salt Pty Ltd exporting solar salt through their Mistaken Island Terminal.
5. Burrup Fertilisers exporting liquid ammonia through the Dampier Port Authority Bulk Liquids Berth.

The five companies operate and maintain their own facilities. Pilotage services are company operated and compulsory for all vessels using the above facilities.

Woodside Energy Ltd provides pilotage services for the Woodside terminals.

Svitzer Australia Pty Ltd provides towage and pilot boat services for the Woodside Withnell Bay and Pluto terminals.

## 1.3 Environment

The islands and waters of the Dampier Archipelago were proclaimed a Marine Park in 2013 under the Australian Environmental Protection and Biodiversity Conservation Act 1999 (EPBC Act) and was renamed Dampier Marine Park in 2017. The management plan and protection measures of the marine park came into effect in 2018. The use of dispersants for any oil spill clean-up is not permitted unless it has been authorised by the designated authority after receiving the advice of the Environmental Protection Authority (EPA).

Masters and owners must be aware of this sensitivity when using the port. Heavy fines will be levied should pollution of any kind occur or should any of the state or port environment regulations or company policies be infringed.

### 1.3.1 Quarantine

Plants or animals, including plant or animal products and other food items, are quarantine items and transfer of these items from vessel to shore is controlled by the Australian Quarantine Inspection Service (AQIS). Woodside Pilots and Loadmasters are not authorised to approve transfer of these items. Where any such items are to be transferred ashore, the ship's Master must arrange for the proper transfer through the ship's Agent and the Australian Quarantine Inspection Service.

## 1.4 Charts and Publications

Relevant charts and publications are:

- Australian Pilot Volume V
- Australian Chart No. 741 (Approaches to Dampier Archipelago)
- Australian Chart No. 57 (Dampier Archipelago)
- Australian Chart No. 58 (Port of Dampier)
- Australian Chart No. 59 (Port of Dampier Northern Sheet)
- Australian Chart No. 60 (Port of Dampier Southern Sheet).

## 1.5 General Weather Information

The Port of Dampier is in a hot, tropical region subject to cyclonic activity.

### 1.5.1 Winds

The prevailing winds are easterly in winter (typically from . to August) and south westerly in summer (typically October to March). The winds can blow more than 20 knots for sustained periods, and periods of sustained winds with diurnal variation is common for the area. During the winter, easterly winds tend to ease late afternoon and during the summer, the south westerly winds tend to ease in the early morning for periods of two to three hours.

### 1.5.2 Cyclones

During the summer months the area can be affected by tropical cyclones. They generally originate in the Timor Sea and follow an erratic South Westerly path. The official season lasts from 1 November to 30 April with, on average, three cyclones each year passing close enough to the area to close the port.

## 1.6 Tides and Currents

### 1.6.1 Tides

Dampier is a standard port in the Australian National Tide Tables (ANNT) published by the Hydrographer of the Royal Australian Navy. The tides in Mermaid Sound are semi-diurnal, with a daily inequality between successive tidal ranges. This inequality can be marked with a potential consequence on departure drafts of laden tankers.

Due to local environmental conditions, the actual and predicted tide readings can vary. A co-relation of the two must be made prior to and during any operations. During cyclonic conditions, this differential can be as much as +2.0 m or -1.2 m.

All tidal and water depth information is referred to chart datum, (LAT: lowest astronomical tide). Table 1 details relevant tidal data for Mermaid Sound.

**Table 1: Tidal Data**

Tide Data	Value
Maximum tidal range LAT to HAT	5.3 m
Mean sea level	2.655 m
MHWS	4.5 m
MHWS	3.2 m

## 1.6.2 Currents

The tidal streams in Mermaid Sound follow a semidiurnal tidal cycle, the flood being generally southerly and the ebb tending northerly. These streams can be affected by wind-generated movement, especially following the passage of a cyclone.

The tides at the berth run parallel to the shore and do not, except in cyclonic conditions, exceed 0.5 knots. In the channel area, the strength of the tidal stream will not normally reach above 1.0 knot, except in cyclonic conditions, where streams of up to 2.5 knots have been experienced. Local anomalies such as late/early change in direction and rapid dissipation/intensification of flows are experienced in this port.

## 1.7 Anchorages

There are three anchorage areas designated for large vessels: the Western Anchorage and the Inner Anchorage (both within port limits) and the Nichol Bay Anchorage (outside port limits). Vessels will be assigned an anchorage by the Dampier Vessel Traffic Service (VTS) prior to reaching port limits. A vessel cannot anchor within the Inner Anchorages without a Pilot on board unless permission is granted by the Port Authority to do so.

For more information, see the Pilbara Ports Authority (PPA) [Port of Dampier Handbook](#).

## 1.8 Prohibited Areas

No vessel or craft, other than with the express permission of the Harbour Master, can enter the following prohibited areas within:

- 700 m of the Woodside jetties
- 200 m of the Woodside Slugcatcher Vent in Withnell Bay
- 200 m of the Dampier Cargo Wharf and Bulk Liquids Berth
- 50 m of the Parker Point, East Intercourse, and Mistaken Island terminals
- 50 m of the wharves at King Bay and Mermaid Marine supply bases.

## 1.9 Gas Trunkline

Three high pressure subsea trunklines have been established on the seabed to supply gas to the onshore treatment plants situated near Holden Point (Pluto) and Withnell Bay. The pipeline routes are marked on charts and are protected by prohibited areas. The Pluto pipeline emerges from the shore and continues out from the port in a north-westerly direction. Prohibited areas are declared for five cables either side of these pipelines.

# 2. WOODSIDE FACILITIES IN PORT OF DAMPIER

## 2.1 Pluto Terminal

The Pluto LNG Terminal lies in the following position: Lat: 20 36 South Long: 116 45 East.

The terminal receives natural gas through a subsea trunkline from fields approximately 180 km offshore. Most of the gas is processed into LNG and condensate for export. LNG is primarily exported to Japan, and condensate is sold on both the domestic and overseas markets.

## 2.2 Withnell Bay Terminal

Woodside Energy Ltd operates the NWSJV Withnell Bay Terminal on the eastern side of Mermaid Sound. This facility lies approximately 3.2 km to the north of the Pluto Terminal. See the [Withnell Bay Terminal Handbook](#) for details.

## 2.3 Loading Facilities

The Pluto Terminal has one loading jetty for the export of LNG and condensate (see APPENDIX M for berth arrangement).

## 2.4 King Bay Supply Facility

King Bay Supply Facility (KBSF) services Woodside offshore facilities and is located at King Bay on the south-eastern side of Mermaid Sound in position 20° 37.6' S 116° 44.8' E. The entrance channel has a declared depth of 5.8 metres above LAT and the berth pocket has a declared depth of 7.5 metres above LAT. There is another Woodside facility on the south-eastern side of KBSF known as the Burrup Materials Facility (BMF), which has a berth pocket with declared depth of 7.6 metres above LAT.

## 2.5 Declared Depths

All stated declared depths within this Terminal Handbook should be confirmed by referencing the current Australian Notices to Mariners and the Pilbara Ports Authority Port of Dampier Local Marine Notices (see [Local Marine Notices - Pilbara Ports Authority](#)).

## 2.6 Woodside and Pluto Channels

Woodside operates buoyed channels to allow safe passage for vessels using the Pluto and Withnell Bay terminals. The start of the Woodside Channel is marked by the Channel Buoy (FL Red 3 secs) in position 20° 26.2' S 116° 43.7' E. The first part of this channel between Channel Buoy and the Woodside No.4 Buoy is shared with the Withnell Bay Terminal. The Pluto Channel extends further southwest from the Woodside No.4 Buoy and turns towards the Pluto Terminal in the vicinity of the P5 and PR1 transit beacons.

### 2.6.1 Sea Buoy

The entrance to the port is marked by the Sea Buoy (Q (4) Y 6s) in position 20° 25.5' S 116° 42.9'. This is a yellow special purpose buoy equipped with a Racon (M) and an Automatic Identification System (AIS) transmitter.

### 2.6.2 Rio Tinto Channel

The Rio Tinto Channel is located to the west of the Woodside and Pluto channels and is used by large bulk carriers sailing from Rio Tinto facilities. The Rio Tinto Channel terminates at the Sea Buoy. Pilot Station B is designated solely for use by Rio Tinto Pilots boarding and disembarking vessels by boat or helicopter.

### 2.6.3 Pilot Boarding Grounds

Woodside terminals use Pilot Station A (20°21.0'S 116°44.0'E) for helicopter transfers and Pilot Station C (20°23.7'S 116°43.7'E) for pilot boat transfers. Inbound vessels should not proceed south of the respective pilot stations without a pilot on board.

The distance from Pilot Station C to the Woodside Channel Buoy is approximately 2.4 nautical miles (NM).

### 2.6.4 Pluto Channel

For more information, see the chartlet in APPENDIX B.

Declared depths vary from 13.7 metres to 11.6 metres above LAT (see Section 2.5).

The approach channel from the Woodside Channel Buoy to the P10 buoy is 8.0 NM long. The inner channel from the P10 Buoy to the swing basin entrance is 2.6 NM long and 250 metres wide.

During Pluto vessel change-outs and Withnell Bay departures, inbound vessels generally transit to the east of the Woodside Channel at reduced speed or stopped until the outbound vessel is past and clear before entering the Pluto Channel north of the P3 Buoy.

### 2.6.5 Woodside Alternate Route

During periods of heavy weather and long period swell, Woodside can use their alternative route for tankers departing from the Pluto and Withnell Bay terminals. This entails standing out to the east of the Woodside channel north of the Woodside No.7 Buoy and then steaming north before turning onto 326° (T) to transit the Rio Tinto Channel (with a declared depth of 15.8 metres above LAT) from the Courtney Shoal Buoy to the Sea Buoy.

### 2.6.6 Swing Basin Manoeuvring Area

The swing basin manoeuvring area for the Pluto Jetty has a declared depth of 11.6 metres above LAT, with a turning circle of approximately 500 metres in diameter.

### 2.6.7 Berth Pockets

The Pluto Jetty berth pocket has a declared depth of 13.2 metres above LAT.

## 2.7 Jetty Facilities

Position: Lat: 20° 36' South Long: 116° 45' East.

The jetty is a single berth loading facility for LNG and condensate tankers, starboard side alongside. The loading platform is equipped with four 16" LNG loading/vapour return arms and two 16" condensate arms.

The berth can accommodate vessels from 180 m to 315 m length overall (LOA). The maximum berthing displacement is 115,000 MT.

**Note:** Condensate tankers at the lower end of this range (LOAs 180 m to 220 m), often known as medium range or MR tankers, require a detailed compatibility analysis to be conducted before they can be considered for this berth.

A gangway to accommodate all tankers is located on the jetty loading platform, and is hydraulically operated in luffing, slewing, and shuttling modes. It is designed to rest on the LNG ship's dedicated strengthened side rails or to rest on the decks of LNG and condensate tankers (see APPENDIX C and APPENDIX D).

Four breasting dolphins with single cylindrical cell rubber fenders and panels extending from LAT +4.0 m to LAT +8.67 m comprise the berth face. Each breasting dolphin is equipped with double release hooks and capstans for spring lines. The maximum berthing speed is 0.15 m/s.

There are aft facing hooks on one of the two forward breasting dolphins for mooring of condensate vessels. There are no forward-facing hooks on the aft breasting dolphins.

Three mooring dolphins, each end of the berth, are equipped with triple and quadruple release hooks and capstans for breast lines.

All hooks are linked to the terminal mooring load and environmental monitoring system (MEMS) and have a safe working load of 125 tonnes. The capstans are two-speed, at a hauling speed of 30 m/min the working load is 30 kN; at 15 m/min the working load is also 30 kN. A maximum load of 60 kN can be pulled for one minute at reduced speed.

### 2.6.1 Freeboard Requirements

This document is protected by copyright. No part of this document may be reproduced, adapted, transmitted, or stored in any form by any process (electronic or otherwise) without the specific written consent of Woodside. All rights are reserved.

Controlled Ref No: XA7500MW0001

Revision: 23

Native file No: 5221942

Page 13 of 73

Uncontrolled when printed. Refer to electronic version for most up to date information.

To ensure sufficient fender contact overlap and gangway operability, all tankers are to always maintain a minimum freeboard of 9.7 m minus the height of the tide.

To ensure marine loading arms are operated within the correct range, all tankers are to always maintain a maximum height of the top of the manifold to water line of 20.1 m minus the height of the tide (top of manifold height = (freeboard + manifold – height of tide) < 20.1 m).

## **2.8 Mooring Load and Environmental Monitoring System (MEMS)**

### **2.8.1 Mooring Load Monitoring**

A mooring load monitoring system is provided for all mooring hooks. The loads are displayed in the Woodside Pilot's office and the terminal central control room (CCR). In addition, the information is transmitted to the tankers and displayed on a dedicated laptop carried by the Pilot.

The system software allows for pre-tension parameters as well as high- and low-level alarm criteria to be displayed and monitored.

### **2.8.2 Environmental Monitoring**

In addition to the mooring load information, the MEMS systems provide environmental data as follows:

- Tidal data
- Current speed and direction
- Wind speed and direction
- Air temperature and pressure
- Relative humidity
- Wave height and period
- Water temperature.

The system also accesses the remote offshore warning system (ROWS), which monitors, predicts, and alarms limiting sea state trends for channel transits and vessels alongside.

## **2.9 Jetty Rules**

During loading the Master is required to ensure that all statutory and company regulations are observed (see the [Pluto Terminal Conditions](#)).

### **2.9.1 Access**

#### **2.9.1.1 Security Alongside**

Vessels will only be accepted to load at the Pluto Terminal if they have a valid International Ship Security Certificate.

Vessels should follow the guidelines contained in their ship security plan to ensure an appropriate security level is always maintained on board. The port and terminal security level in force will be communicated to ships prior to their arrival and, where necessary, additional security measures agreed in a Declaration of Security before the vessel's arrival.

The terminal has strict access controls in accordance with its facility security plan and reference should be made to APPENDIX N for details of requirements.

### 2.9.1.2 Security and Control of Tanker's Personnel

Control of personnel access to the tanker will be through the security personnel at the Pluto Terminal main gate (see APPENDIX N for further details).

### 2.9.1.3 Access through the Terminal

Access to the tanker through the terminal is strictly controlled. Pedestrian traffic is prohibited between the jetty and the main gate. The jetty is deemed secure under maritime security legislation and is accessed through electronically operated gates.

Vehicle access to the jetties is strictly controlled, and only approved vehicles are allowed to operate within the terminal.

The Master is required to sign acceptance of the Security Arrangements for Ship's Crews (see APPENDIX N) prior to berthing. The appointed Shipping Agent will provide the Master with details of available transport services. Arrangements for alternative transport, such as an approved bus service, can be arranged through the Agent.

Masters of tankers are reminded that intoxicated persons are not permitted access through the terminal. Random breath testing is in force at this terminal, and anyone producing a sample of 0.04 BAC or above will not be allowed onto the site. The ship's Agent will be informed and will have to collect the person from the main gate.

### 2.9.1.4 Actions following Muster Signal

Actions to be followed during Emergency Muster either in the terminal or onboard tankers:

- When the muster signal sounds, Pilots and Loadmasters on board tankers must report their whereabouts to the relevant main gate security team so that they can be included in the site muster. This is particularly the case when the Pilot has arrived on board the tanker at sea and will not appear on the site muster manifest.
- Similarly, the Pilot/Loadmaster on board the tanker is to account for any visitors embarked on board the tanker such as Agents, Surveyors, Buyer Representatives, and other visitors. The muster of such persons on board the tanker must be relayed to terminal security.
- All non-ship's personnel embarked on board vessels while alongside a terminal or within port limit limits must muster and remain on board the tanker until the all-clear has sounded or an alternative instruction is given from either the Terminal Representative (Loadmaster) and the Tanker Master.
- If the Pilot/Loadmaster and Tanker Master consider it unsafe for visitors to remain on board the tanker, actions to remove visitors from the vessel and to a terminal muster point will be advised to the visitors, escort arranged, and security notified.
- Pilots, Loadmasters, ship's crew, or visitors who are in transit through the terminal should proceed to, and report at, the nearest designated muster point and remain there as instructed.

The location of emergency muster points:

- remain at muster on board the tanker (in accordance with above)
- wherever there is a green flag indicating muster point
- at Pluto, the nearest muster point is the FAR at the jetty carpark.

In the event of unavailability of the loading jetty or gangway for disembarkation of tanker personnel and visitors, the ship's lifeboats, or the offside accommodation ladder, can be used to remove personnel from the tanker. This will be conducted only in exceptional circumstances and will be covered by the tanker's muster and emergency evacuation procedures.

## 2.9.2 Stores

Due to vehicle access restrictions and jetty configuration, only storing of hand-carried items is allowed. A reasonable quantity of goods which can be hand carried down the jetty is a single pallet that can be broken down and hand carried across the gangway.

Under certain circumstances stores/mechanical spares can be arranged, by the vessel Agent, for delivery by boat. Terminal permission is required, delivery times are restricted, and cargo operations cannot be compromised by this operation. If permission is not granted, stores can be delivered at inner anchorage or outer anchorage by the boat arranged by the Agent.

Tankers visiting the Pluto Terminal can take stores from stores boats on the outboard side while alongside, provided that the following criteria are met:

1. The storing operation must not compromise the loading schedule of the tanker. Storing will be permitted from time of "all fast alongside" until the tanker is ready to commence arm cooldown (LNG vessels). If storing is not completed within this timeframe, the storing will be suspended until completion of loading (loading arms liquid free in the case of LNG vessels). The alternative is to complete stores at the outer anchorages prior to/post pilot embarkation/disembarkation.
2. Small vessels and workboats used for alongside storing at any Woodside-operated terminal must be compliant and current with Woodside Marine Assurance vessel vetting process. No other third-party vessels will be permitted.
3. The tanker and workboat must comply with all other relevant safety, security, and environmental regulations of the terminal, the port authority, and the respective vessel's safety management system (SMS).
4. The tanker and workboat must comply with all other relevant safety, security, and environmental regulations of both the terminal, the port authority, and the respective vessel's safety management system (SMS).
5. No liability or protest will be accepted on behalf of the terminal operator or Woodside Marine for restrictions, damages, incidents, or other form of loss arising from the storing operation alongside.

## 2.9.3 Engine Repairs

No engine immobilisation is allowed alongside the berth. With the Harbour Master's approval, limited repairs can be allowed at the anchorage. It is unlikely that approval will be given during the cyclone season (November to April).

## 2.9.4 Fresh Water

Not available

## 2.9.5 Bunkers

Not available

## 2.9.6 Liquid Nitrogen

Not available

## 2.9.7 Gangway

A shore gangway is provided on the jetty. Ship's personnel are required to assist in this operation with respect to the placement of the gangway.

Masters of tankers should be made aware that the shore gangway is to be considered as a ladder rather than a stairway. Arrangements must be made to ensure the safety of personnel is not compromised when the gangway is used in the transfer of stores or crew baggage.

### 2.9.8 Lifeboat Drills

While it is recognised that there might be a need to conduct lifeboat drills, for reasons of terminal safety and security, it is not permitted to put lifeboats into the water while alongside the jetty.

### 2.9.9 Tanker Emergency Equipment Testing

Lifeboat engines, emergency fire pumps, and emergency generators can be tested to allow for compliance with Port State control requirements. These tests should be planned to occur before or after any hydrocarbon transfer, to minimise any impact to the ship's loading schedule.

### 2.9.10 Australian Government Requirements

Prior to arrival at the terminal, the Master must ensure the vessel meets all Australian Government requirements, including compliance with the [Australian Biosecurity Act 2015](#) and the Department of Agriculture, Fisheries and Forestry [Australian Ballast Water Management Requirements](#). More information can be sought from approved Australian agents.

Pratique requirements must be confirmed by approved Australian agents, including any special customs and immigration requirements. Pratique requirements must be met/complied with before a vessel visits the terminal.

### 2.9.11 Ballast Water Discharge Management

All arriving tankers at the Woodside terminal must comply with the [Australian Biosecurity Act 2015](#) requirements for ballast water management for vessels arriving into Australian economic exclusive zone (EEZ). This includes compliance with compulsory exchange of ballast water prior to arrival into Australian waters for those vessels not fitted with a class approved and operational ballast water treatment system (BWTS). Those vessels fitted with a class approved BWTS will have submitted a copy of the ballast water management certificates as evidence, as part of the Woodside Assurance Process.

**Note:** Discharge of ballast tank sediment is an offence in Australian waters. A tanker can use ballast eduction to remove residual ballast water to an acceptable level provided its use will not result in the increased risk of discharge of ballast tank sediment.

See the Department of Agriculture, Fisheries and Forestry [Australian Ballast Water Management Requirements](#) for more information.

### 2.9.12 Discharge of Open Loop Exhaust Gas Cleaning Systems

The Pluto LNG Terminal is in an environmentally sensitive area and, as such, the discharge of closed loop wash water is not permitted at the terminal. See the Australian Maritime Safety Authority (AMSA) [Marine Notice 2022/12 – Requirements for the use of exhaust gas cleaning systems in Australian waters](#) and reporting to AMSA for further information.

## 3. COMMUNICATIONS

Table 2 outlines the contact information that applies to the Pluto Terminal.

**Table 2: Pluto Terminal Contact Details**

Contact Method	Details
Email	<a href="mailto:pilotloadingmaster@woodside.com.au">pilotloadingmaster@woodside.com.au</a>
Duty pilot mobile	+61 438 993 420

This document is protected by copyright. No part of this document may be reproduced, adapted, transmitted, or stored in any form by any process (electronic or otherwise) without the specific written consent of Woodside. All rights are reserved.

Controlled Ref No: XA7500MW0001

Revision: 23

Native file No: 5221942

Page 17 of 73

Uncontrolled when printed. Refer to electronic version for most up to date information.

Phone	(08) 9158 7153 / 7154 / 7159 / 7076
Notes	Pluto Main Gate is manned on a 24-hour basis. Urgent, out-of-hours messages can be forwarded to (08) 9159 0160.

### 3.1 Communications Plan Dampier

Table 3 outlines the communications plan for Dampier.

**Table 3: Communications Plan Dampier**

Area	Communication Channels
Pilbara Ports Authority	The Dampier VTS tower is manned 24 hours a day. Routine operational communications, such as Pilot on Board notification, intended movements, and planned routes or clarification between vessels, are to be communicated directly from each vessel through the working channel. Any port-related safety or emergency issues should be communicated directly to "Dampier VTS", who are required to respond immediately. <ul style="list-style-type: none"> <li>VHF Channel 11 Calling</li> <li>VHF Channel 11 Working</li> </ul>
Woodside radio	VHF Channel 82 – general working and calling channel
Pilotage (Woodside terminal)	VHF Woodside "Port Ops" Channel (Duty Pilot mobile: 0438 993 420)
Tug standby channel	Tug mobile phones
Port emergency frequency	VHF Channel 79
Cargo loading	Dedicated UHF LNG and LPG/condensate loading channels

#### 3.1.1 Pre-Arrival Communication

To assist in terminal planning and to satisfy port regulations, the following pre-arrival messages (Section 3.1.2) are to be sent to the tanker's Agent, as detailed. The Agents have instructions regarding the distribution of messages.

Prior to a tanker's arrival at a Woodside facility, the relevant terminal conditions will be sent to the tanker's Master, along with the pre-arrival information (72 hours before the scheduled pilot boarding time). The tanker's Master is to sign and return the terminal conditions to the Pilot Loading Master inbox ([pilotloadingmaster@woodside.com.au](mailto:pilotloadingmaster@woodside.com.au)) at least 24 hours prior to the scheduled pilot boarding time. The acknowledgement of terminal conditions must be met with no comments/restrictions and limitations (i.e. it must be a clean acknowledgement).

Failure to do so can result in delays to berthing and loading the tanker.

#### 3.1.2 Tanker Pre-Arrival Messages

Table 4 outlines the information required by the terminal which is sent to the tanker's Agent by all tankers using the facility.

**Table 4: Tanker Pre-Arrival Messages**

Period	Action
On departure from last port of call (in any event no less than five days prior to arrival)	Answer Pluto Questionnaire (see Section 3.2 for LNG tankers and 3.3 for condensate tankers).
Seven days prior to arrival	Advise the estimated time of arrival (ETA) and arrival draught for Dampier.

Period	Action
Three days prior to arrival	Advise ETA.
Two days prior to Arrival	<ol style="list-style-type: none"> <li>1. Advise ETA, arrival, and departure draughts.</li> <li>2. Confirm all cargo systems operational.</li> </ol> <p><b>Note:</b> Any changes in ETA of more than six hours after the seven-day ETA should be immediately notified.</p>
24 hours prior to arrival	<p>Confirm ETA.</p> <p><b>Note:</b> Tanker Masters are requested to send the 24-hour ETA and any changes of more than one hour within 24 hours of arrival to the Pilot direct in addition to the Agent. Masters must also consult their Charterer's instructions in this regard.</p>

The tanker's Agent is to forward the information to the Pilot, Shipping Office, and Offtake Coordinator.

Email [pilotloadingmaster@woodside.com.au](mailto:pilotloadingmaster@woodside.com.au)  
 Telephone +61 8 9158 7153 / 7154 / 7159 / 7076 / 7110  
 Emails [??shippingofficeplant@woodside.com.au](mailto:??shippingofficeplant@woodside.com.au)  
[Pluto LNG Offtake@woodside.com.au](mailto:Pluto_LNG_Offtake@woodside.com.au)

### 3.1.3 Arrival Port of Dampier Limits

The requirements are:

- All vessels within the VHF range of the Port of Dampier are required to monitor VHF channels 16 and 11 for information regarding the movement of other vessels arriving at, or departing, from the port.
- Two hours prior to arriving at port limits, vessels must contact Dampier Port Communications and advise their ETA at port limits and any other relevant information, such as intention to anchor, ship's security level, expected time of Pilot boarding, etc.
- The Pilot will contact the vessel one hour prior to the scheduled Pilot boarding through VHF Channel 11.
- There is a recommended fairway in use to the north of the port and all vessels are encouraged to use this fairway (see APPENDIX A).

### 3.2 Pluto Terminal Pre-Arrival Questionnaire (LNG Carriers)

The ship's Agent is to provide an electronic copy of their 72-Hour Pre-Arrival Questionnaire. See APPENDIX P for an example questionnaire for LNG carriers.

If, at any stage of the ballast passage, it becomes apparent that the vessel might not be able to meet the ETA, as instructed by the Charterer, Woodside Pilots must be informed as soon as possible. This is so any exposure to tank-tops can be evaluated.

If the vessel is unable to comply with the requirements of the applicable charter party for arrival tank temperatures, Woodside Pilots must be advised as soon as possible. For example, on MOSS vessels, if any of the arrival tank temperatures will be warmer than **-110 °C**, and on Membrane vessels, if any of the arrival tank bottom temperatures is warmer than **-130 °C**, Woodside Pilots must be informed as soon as possible so that any exposure to tank-tops can be evaluated. Arrival cargo tank pressures should be controlled to be targeted at less than 14 kPa, but ideally around 10 – 11 kPa, if possible.

The Pilots' office must be advised of any problems associated with cargo systems, navigation equipment, moorings, etc., as early as possible, to allow for contingencies to be developed to avoid delays to LNG tanker schedules.

### 3.2.1 Sequence of Messages

Table 5 outlines the sequence of messages and the information provided in each message.

**Table 5: Sequence of Messages**

Period	Information Provided
On departure from the discharge (or repair) port	<ul style="list-style-type: none"> <li>Ship's name</li> <li>Date and time of Full Away On Passage (FAOP) from their discharge port</li> <li>Date and time of arrival (ETA) at the Pilot boarding point in Dampier</li> </ul>
Seven days prior to arrival	<ul style="list-style-type: none"> <li>Date and time of arrival (ETA) at the Pilot boarding point in Dampier</li> <li>Estimated tank temperatures on arrival and tank cool down period required</li> <li>Expected arrival draft</li> <li>Earliest possible ETA at Dampier</li> </ul>
Five days prior to arrival	<ul style="list-style-type: none"> <li>Date and time of arrival (ETA) at the Pilot boarding point in Dampier</li> <li>Estimated tank temperatures on arrival and tank cool down period required</li> <li>Earliest possible ETA at Dampier</li> </ul>
Three days prior to arrival	The ship's Agent is to provide an electronic copy of the 72-Hour Pre-Arrival Questionnaire. See APPENDIX P and APPENDIX Q for examples of questionnaires for LNG and condensate vessels.
Two days prior to arrival	<ul style="list-style-type: none"> <li>Date and time of arrival at the Pilot boarding point in Dampier</li> <li>Estimated quantity of LNG on board on arrival</li> <li>Volume of LNG cargo to load</li> <li>Any requirements that could extend the vessel's stay in port beyond what is required to load the cargo</li> </ul>
One day prior to arrival	<ul style="list-style-type: none"> <li>Ship's name</li> <li>Date and time of arrival at the Pilot boarding point in Dampier</li> <li>Estimated tank temperatures and cooldown period required <ul style="list-style-type: none"> <li>Any changes of more than one hour in the ETA after the 24-hour ETA should be immediately copied directly to the Pilot as well as the ship's Agent.</li> <li>The weather forecast for Mermaid Sound will be sent to the vessel approximately 24 hours prior to arrival.</li> </ul> </li> </ul>
Arrival at Port of Dampier limits	Notice of readiness (NOR) should be tendered at the time the Pilot boards. If the vessel has arrived off the port at the time instructed by the Charterer and is not required by the terminal to proceed directly to the berth, the time that the vessel anchors at the outer anchorage can be submitted as NOR. NOR acceptances will be stamped for "Receipt Only" by the Pilot at the time of Pilot boarding. NOR will be noted on the Pilot's port time sheet.

### 3.3 Pluto Terminal Pre-Arrival Questionnaire (Condensate Tankers)

The ship's Agent is to provide an electronic copy of the 72-Hour Pre-Arrival Questionnaire. See APPENDIX Q for an example questionnaire for condensate tankers.

The pre-arrival questionnaire must be completed by all condensate tankers on departure from the last port of call (in any event, to be received at least five days prior to arrival).

### 3.4 Port Health

Radio Pratique is in force for the Port of Dampier. Vessels should send a Radio Pratique message to their Agent not more than 48 hours or less than 24 hours before arrival.

#### 3.4.1 Quarantine Anchorage

Should Radio Pratique not be granted, the Harbour Master will advise an anchorage position if the vessel is not berthing on arrival.

### 3.5 Weather Reports

While at anchor, vessels should monitor weather reports. Urgent reports will be passed on request to the vessel by Dampier Port Communications (VHF 16 – 11). While alongside, reports of an urgent nature will be passed to the vessel through the Pilot.

### 3.6 Communication Terminology

The communication terminology in Table 6 applies to all ship/shore communications.

The terminology is intended to ensure uniformity in calling and important message relays, such as loading rates, etc.

The Pilot will ensure the terminal CCR has the correct name of the tanker when making first contact.

**Table 6: Communication Terminology**

Message	Terminology
Tanker calling the terminal CCR	Terminal/Terminal/"Vessel Name"
Pilot calling the mooring party	Jetty/Jetty/Pilot
Tanker calling the Jetty Operator	Jetty/Jetty/"Vessel Name"
Terminal CCR calling the tanker	"Vessel Name"/"Vessel Name"/Terminal
Mooring party calling the Pilot	Pilot/Pilot/Jetty
Jetty Operator calling the tanker	"Vessel Name"/"Vessel Name"/Jetty

All loading rates will be in cubic metres each hour at 15 degrees Celsius.

Unless otherwise specifically stated, all pressures will be in kPa.

## 4. SHIP COMPATIBILITY AND ASSURANCE

All vessels scheduled to load at Pluto Terminal will be subject to a compatibility and assurance approval process which, if successful, will approve the vessel for a single, or multiple, terminal visits. The compatibility and assurance process will review the suitability of the vessel prior to arrival in terms of management capability and performance and the physical attributes of the ship against the infrastructure of the terminal. Aspects under consideration will include, but are not limited to, the following:

- Vessel size and displacement

This document is protected by copyright. No part of this document may be reproduced, adapted, transmitted, or stored in any form by any process (electronic or otherwise) without the specific written consent of Woodside. All rights are reserved.

Controlled Ref No: XA7500MW0001

Revision: 23

Native file No: 5221942

Page 21 of 73

Uncontrolled when printed. Refer to electronic version for most up to date information.

- Compatibility with the jetty fender/mooring systems
- Arrival and departure draft
- Compatibility with gangway access, marine loading arms, and emergency shutdown systems
- Total windage, vessel manoeuvring characteristics, and bridge visibility from the conning position
- Suitability of towage fittings
- Operator history
- Class or flag state restrictions.

Terminal approval can be withdrawn should a vessel fail to meet the expectations of the terminal.

#### 4.1 Sanctions Assessment Procedure

International and Australian sanctions can impact the ability of operator, lifting parties, and others to undertake or participate in product offtake activities at Woodside-operated facilities. For assisting the Operator to comply with these requirements only, Marine Assurance undertakes a process (based on the information available to Marine Assurance) to assess whether any sanctions exist against a vessel or relevant person and, in some circumstances, the Operator might require additional information or explanation from the relevant lifting party. The Sanctions Assessment Procedure (see APPENDIX R) prescribes the form in which this further information or explanation can be sought (i.e. with completion of a pro forma declaration). Lifting parties should also undertake their own process to ensure they comply with any International and Australian sanctions that might apply to their role in respect to product offtake activities at Woodside-operated facilities.

The Operator undertakes to give prior notice in writing of the requirement for a declaration to be completed by the lifting party (this will be driven by the Marine Assurance team's checks in respect of a vessel) and, in turn, requires any change in circumstances after submission of the declaration be communicated by re-submission of a new declaration.

The Operator can withhold, suspend, or terminate provision of marine services in support of product offtake (including pilotage) and require the removal of any vessel from a berth, considering responses in the declaration (or re-submitted declaration) or the Operator's own and ongoing sanctions assessments.

## 5. BERTHING ARRANGEMENTS

### 5.1 Pilotage

Pilotage is provided by Woodside Marine Operations. Pre-arrival information will be forwarded to vessels by the Pilots several days prior to their arrival in Dampier.

#### 5.1.1 Pilotage Requirements

Pilotage is compulsory for all tankers using the Pluto terminal.

Woodside terminals use Pilot Station A (20°21.0'S 116°44.0'E) for helicopter transfers and Pilot Station C (20°23.7'S 116°43.7'E) for pilot boat transfers. Inbound vessels should not proceed south of the respective pilot stations without a Pilot on board.

#### 5.1.2 Pilot Boarding Requirements

Personnel transfer is a high-risk operation, and Woodside expects strict adherence to the relevant international instruments, including:

- IMO Resolution A.1045(27)

- SOLAS Regulation 23
- Section 7 Pilot Transfer Arrangements
- the IMO/IMPA Pilot Ladder Poster (see APPENDIX F).

Relevant guidelines and directives contained in current [AMSA Index of marine notices](#) and the [Pilbara Ports Authority Port of Dampier Local Marine Notices](#) must also be strictly observed.

Woodside does not accept any pilot ladder arrangements of a trapdoor design for the transition between the rope ladder and combination gangway.

A Responsible Officer must inspect the pilot boarding arrangements and confirm the ladders are clean, of sound construction, are correctly rigged in accordance with the legislative instruments, and as directed by the Pilot. A Deck Officer must supervise the personnel transfer from the upper deck.

For the application of IMO Resolution A.1045(27) to existing ships (pre-2012):

- Woodside Port Operations' strong preference is for a physical load test of the securing points for pilot ladder and man ropes.
- ISO 799-3 (2022) should be consulted and applied when determining the strength of the deck securing points.
- Ships compliant with A.1045(27) or with a delivery date on or after 1 July 2012 should be deemed to meet requirements.

For all other ships, the strength of the pilot ladder and man ropes securing points should be demonstrated (in order of preference) by at least one of the following methods:

- Independent physical load test and certificate.
- Shipyard as built drawings clearly stating the SWL of the strong points.
- Classification Society statement specifying the pilot ladder securing points achieve the intended strength requirement of ISO 799-3 – Section 5.

Regardless of ship delivery date or compliance with resolution A.1045, it is recommended that the strong points are tested at Special Survey every five years.

All pilot ladders used to board or disembark a ship at Woodside terminals must be constructed and rigged in accordance with SOLAS regulations, including:

- being independently lashed to the rated strong points on deck (not handrails)
- the ladder and gangway being secured appropriately to the vessel's hull
- each ladder having a SOLAS compliance plate attached, with certification stating the ladder has been constructed to comply with SOLAS and ISO 799 regulations
- being no more than 30 months old (from date of manufacture)
- the ladder winch reel locking-off arrangement must be engaged with supplementary lashings securing the pilot ladder to rated strong points on deck.

**Note:** Vessels rigging combination arrangements are exempted from Section 7.4.3 of IMO Resolution A.1045(27); the terminal will permit pilot ladders to be secured inboard at a horizontal distance of less than 915 mm when rigged as a combination ladder.

Ladders not stowed on pilot ladder reel arrangements must be secured to rated strong points on deck by two separate means, which can involve one or two pairs of ancillary lines secured by rolling hitches to each side rope of the ladder if the side rope termination thimbles cannot be shackled directly to the strong points on deck.

Manropes must not be used for Pilot transfers beyond 12 months from the date of manufacture. Other ancillary ropes, including independent upper deck lashings and shipside lashings, should also

be certified and renewed no later than 12 months from the date of first use, as recorded in the ship's planned maintenance system (PMS).

Ensure corrosion-induced wear in stanchion fittings, collapsible side rails on gangways, and their platforms does not result in unstable handholds or instability underfoot.

The bottom of the ladder must be positioned 2.0 metres above water level with manropes available as required by the Pilot (SOLAS 7.1.1).

A suitable lee must be provided for the safe embarkation of personnel and equipment.

## 5.2 Terminal Representative

The Pilot/Loadmaster acts as both Pilot and Terminal Representative on all tankers. The Pilot/Loadmaster is responsible to the company for ensuring its requirements regarding the safe mooring and loading of the tanker are observed while the tanker is alongside the berth. The Pilot has a responsibility to the Harbour Master for ensuring the requirements of the Pilbara Ports Authority Regulations are observed. A Loadmaster is assigned to the vessel throughout the loading operations. Tankers are required to provide suitable accommodation for the Loadmaster (Pilot).

The Pilot/Loadmaster is required to ensure the good liaison and communications, essential for a safe and efficient operation, are maintained between the tanker's staff and the terminal. The Pilot/Loadmaster is to ensure any concerns, comments, or advice from either the tanker's Master and Officers or the terminal are followed through in an appropriate manner.

It is incumbent on the Master to ensure full cooperation with the Pilot/Loadmaster to ensure a safe and efficient operation.

## 5.3 Channel Transit

Tankers, unless for reasons of safety or as specified by the Harbour Master, should remain within the designated Pluto Terminal Shipping Channel when proceeding to or from the terminal.

At all times while manoeuvring, the vessel should monitor VHF Channels 11 and 82 in addition to the terminal's UHF Pilotage Channel.

### 5.3.1 PPU Berthing Aids

As part of a service agreement, the Pilot will carry a portable GPS unit. This equipment is used as a berthing aid, including jetty approach speeds.

### 5.3.2 Transit Criteria and Weather Limitations

Due to the sustained wind patterns that affect the Port, it might be necessary, where this is possible, for the Pilot to request a tanker to increase her arrival ballast draught.

The actual decision to berth a vessel depends on many factors, which can only be assessed by the Pilot and Master in conjunction. In any event, no vessel will be berthed in wind speeds more than 30 knots.

High windage LNG vessels are wind limited, as defined by their cargo capacity, and whether the vessel in transit to or from of the berth (see APPENDIX K).

Depending on the circumstances, winds of less than 30 knots can be restrictive to a tanker berthing operation. The direction and speed of any tidal or induced current will be considered when berthing decisions are made.

Prior to loading operations and any inward or outward transits, the Pilot will, if required, confirm the actual sea state against the forecast to ensure the planned under keel clearance (UKC) is correct and can be maintained.

Requirements of the terminal's cyclone procedures take precedence over these criteria.

### 5.3.3 Inward Transits

During the inward transit and prior to committing a vessel to entering the final leg of the channel, the Pilot must ensure that terminal staff will be available to commence mooring the ship at the time the vessel arrives alongside.

As part of the inward procedure, the terminal CCR must be contacted prior to the turn at the Number P8 Beacon and provided with an estimated time the vessel will be alongside. If the terminal is unable to provide a mooring crew at the scheduled time, the inward transit must be suspended until confirmation is received that a mooring crew will be available.

### 5.3.4 Outward Transits

When sea states exceed (or are predicted to exceed) the maximum criteria for a reef crossing off the Woodside Channel Buoy, all vessels must depart through the Woodside alternate route.

The following track should be observed when the alternate route is used: Upon passing the Woodside No.7 Buoy, alter course to starboard to bring Legendre Island light dead ahead on a course of around 035°(T). Head north after clearing the Woodside No.6 Buoy before altering course to port onto a course of 326°(T) to transit the Rio Tinto Channel (declared depth 15.8 metres at LAT) from the Courtney Shoal Buoy to the Sea Buoy.

The deviation to the east of the Woodside Channel is necessary to avoid a shoal patch east of the Woodside No.6 Buoy and must always be observed. Occasionally, alternate departure route transits will be undertaken to maintain Pilot familiarisation.

## 5.4 Transit Restrictions for Vessel (LNG/Condensate)

Transit restrictions are detailed in APPENDIX K, which defines operational parameters for maximum wind and number of tugs for berthing and departures at the Pluto Terminal. Vessel wind limits are based on vessel type, allocated jetty, size, displacement, UKC, and windage, and are determined during the terminal compatibility process.

## 5.5 Transit Speeds

Transit speeds for the vessels are based on the model and computed response characteristics of the vessels with respect to squat and vertical motion as well as the other parameters used in determining a minimal under keel clearance for the entire tidal range.

Simulation results have shown that speeds in excess of those in Table 7 and Table 8 degrade the ability to effectively respond to a loss of steering or engine failure.

Should maximum sectional speeds be exceeded, a *Marine Event Report* will be generated for analysis purposes.

**Table 7: Maximum Transit Speed for Arrival Tankers (UKC ≥ 2.0m)**

Passage Section Inwards	Description	Max. Sectional Speed
Approach Track	Sea Buoy to P3 Buoy	Safe speed
Pluto Bend	P3 Buoy to P12 Buoy	10 knots
PLP Inner Channel	P12 Buoy to P16 Buoy	8 knots

Passage Section Inwards	Description	Max. Sectional Speed
PLP Swing Basin	P16 Buoy to Berth	5.5 knots

\*Max sectional speed in the vicinity of No. P10 to No. P11 can be exceed by ½ knot, if required by the prevailing environmental conditions.

**Table 8: Maximum Transit Speed for Departure Tankers (UKC ≥ 1.5)**

Passage Section Outwards	Description	Max. Sectional Speed
PLP Swing Basins	Berth to P16 Buoy	5.5 knots
PLP Inner Channel	P16 Buoy to P12 Buoy	8 knots
Pluto Bend	P12 Buoy to P3 Buoy	10 knots
Approach Track	P3 Buoy to Sea Buoy	Safe speed

## 5.6 Tanker Drafts

### 5.6.1 Inwards Draughts – LNG Tankers

Inbound tankers must operate at drafts that are within normal operating parameters and must maintain a minimum static UKC of 2.0 metres.

To provide for 24-hour non-tidal restricted berthing, condensate tankers arrival draft should not exceed 10.0 metres and the vessel's trim should not exceed 3.0 metres.

### 5.6.2 Minimum UKC Alongside

A minimum UKC of 1.0 metre must be maintained at all berths.

### 5.6.3 Outwards Drafts

Outbound tankers must operate at drafts that are within normal operating parameters and must maintain a minimum static UKC of 1.5 metres.

## 5.7 Towage Services

All tankers berthing at the Pluto Terminal will use the services of the tugs provided by Svitzer Australia Pty Ltd. This service is provided under the terms and conditions of the UK Standard Conditions for Towage and Other Services (UKSTC) (1986 as amended). Towage services will only be provided upon acknowledgement of this condition.

### 5.7.1 Tug Fleet

The tug fleet consists of 5 x 80 tonne bollard pull RAstar 2800 tugs.

### 5.7.2 Allocation of Tugs

The five-tug fleet is scheduled by Svitzer Australia Pty Ltd to meet the total shipping needs of both Withnell Bay and Pluto terminals.

Allocation of any tugs within this fleet will be based on good port practices to ensure the most efficient use of tugs and the port operation.

The Port Operations Superintendent (POS) will coordinate and have the final call for shipping movements for the two facilities taking the following into account:

- Proximity of cyclones, as described in the cyclone procedures.
- Size of the weather window at any time of the year.

- Proximity of squall and other high wind events, which can disrupt normal shipping activities.
- Workforce constraints.
- Tug constraints in the event of breakdowns, maintenance, or dockings.

### 5.7.3 Tug Requirements

For planning purposes, the minimum tug numbers prescribed in APPENDIX K should not be reduced unless extenuating circumstances arise. In the event, an operational risk assessment will be required for this during the planning phase.

If the Pilot and Tanker Master consider an increase in tug numbers is appropriate, early advice is generally required to facilitate this without delays.

For more information, see APPENDIX K.

### 5.7.4 Tugs on Station

The securing and placement of tugs will always be dictated by logistical and environmental considerations. However, the following standard practice for arriving and departing tankers has been developed, with important safety considerations taken into account:

- For inbound tankers, one tug will meet the tanker at the P3 Buoy and make fast aft. Two shoulder tugs will meet the tanker before passing the P6 Buoy and escort until making fast, in accordance with the Pilot's direction. The fourth (and, if required, fifth) tugs will meet the tanker after passing the P10 Buoy and make fast in accordance with the Pilot's directions.
- For outbound tankers, the tugs will normally escort the tanker to the P8 Buoy. The tug aft should remain secured until this point is reached. However, the Pilot or Tanker Master can retain the tug escort to any point deemed appropriate.

### 5.7.5 Securing of Tugs

All tugs will be made fast using tug's lines with messenger lines attached. When letting go tugs, the towlines must be lowered down in a controlled manner. Tug towlines must **not** be dropped.

### 5.7.6 Standby Tug Duties

For tanker and terminal safety, at least one tug will remain on standby in the tug pens at the King Bay Supply Facility while a tanker is alongside any of the berths. Additional standby tugs might be required due to berth occupancy and environmental factors. Standby tugs might be called out to take up positions off berth exclusion zones or alongside the tankers.

## 5.8 Mooring Requirements

All vessels moored at this terminal should conform to the requirements contained in the [OCIMF Mooring Equipment Guidelines 4<sup>th</sup> Edition \(MEG4\)](#), particularly with respect to Section 3 – Mooring Forces and Environmental Criteria.

For LNG tankers, the mooring requirements will be assessed individually. Generally, these will be more conservative than for a condensate tanker of the equivalent size.

### 5.8.1 Mooring Integrity

The Tanker Master is responsible for providing adequate mooring lines and ensuring that they are properly tended while the tanker is alongside. Swell induced movement can cause very high mooring loads. Minimum mooring requirements have been determined based on mooring studies associated with the berths at Withnell Bay.

The Master and Pilot must agree that the tanker is effectively moored prior to the commencement of cargo operations. The Pilot must inform the Master or his deputy if he has any concerns regarding the moorings, with respect to moorings bearing an even strain.

Cargo operations should be stopped if there are any concerns about the mooring system integrity, including failure or inability of the tanker to keep the moorings satisfactorily tensioned, with all lines bearing a suitable and even strain but not over-tensioned.

Dampier is essentially an open, unprotected port. Berth operability graphs are monitored on board tankers using an iPad supplied by the Pilot/Loadmaster, which also displays mooring line tensions. If predictions indicate the sea state will exceed berth operability curves, then this should be brought to the Pilot/Loadmaster's attention. This is most likely to occur during periods of long period swell, with Hs (wave height) exceeding 0.3 metres and Tp (wave period) exceeding 15 seconds.

### 5.8.2 Mooring Tensions

All mooring hook loads are monitored in the terminal CCR. In line with mooring requirements, all mooring lines should be pre-tensioned. Tensions on each hook will be relayed to the Pilot by the terminal CCR during the mooring operation for the purpose of ensuring an even tension on all lines.

### 5.8.3 Condensate Tanker Minimum Requirements

1. All wires and ropes should be on winches. No ropes on bitts will be allowed.
2. All wires and HMPE ropes are to be fitted with suitable tail lines. No mixed moorings will be allowed.

**Note:** Vessels fitted with a complete mooring system of HMPE ropes of comparable MBL and characteristic to wires will be treated as a ship with all wire moorings with respect to Class A and B requirements. HMPE moorings are otherwise treated as synthetic moorings in relation to MBL requirements.

### 5.8.4 Condensate Tankers' Mooring Requirements

TANKER SIZE	WIRE	HMPE	LINES REQUIRED	
	MBL (tonne)	MBL (tonne)	Fore	Aft
<b>90 – 150</b> (DWT x 1000 t)	80	89	2+2+2	2+2+2

MBL = Minimum Breaking Load

If a vessel does not comply with these mooring requirements, a mooring analysis can be required for acceptance to ensure mooring integrity.

### 5.8.5 Mooring Lines

The following are the requirements for all mooring lines:

- All mooring lines used by vessels are to be in good condition, with no joins (splices, knots, bends, or shackles) in them.
- Mooring lines are to be kept tight and the ship kept firmly alongside and parallel to the fender line.
- During adjustment of mooring lines, it is essential the ship's position alongside with respect to the spotting line is maintained.
- Ship mooring lines are to be properly tended 24 hours each day by a competent person while a vessel is moored alongside.

- Regular checks are to be made to ensure lines have an even tension.
- The use of wire mooring tails is prohibited.
- Under no circumstances is wire line to be made fast to a bollard.
- Standing lines and lines to winch drums must be deployed symmetrically fore and aft.

### 5.8.6 Running of Mooring Lines

Vessels will only be allowed to run one mooring line at a time even though a dual headed messenger line can be used. This will be advised and discussed during the Master Pilot exchange. See APPENDIX J for details of running of mooring lines.

Each of the spring lines (forward and aft) is to be run by passing a heaving line to the outer end breasting dolphin, to which the jetty mooring crew will attach a messenger rope. The messenger rope will be retrieved onto the ship and attached to mooring line tail rope, about a metre from the shore side eye of the tail. In the case of spring lines, heaving lines should not be passed back to the shore by re-attaching them to the mooring or messenger lines, as they often foul during the deployment process. This fouling significantly increases hazard levels on the mooring dolphins.

- **The first breast line** at each end (forward and aft) will be retrieved onto the ship by a heaving line in a similar fashion to the retrieval of the spring lines.
  - The ship's crew pass a heaving line to the outer end breasting dolphin to which the jetty mooring crew will attach a messenger rope, which is then taken to the poop deck. Heaving lines must remain attached to the messenger while running remaining mooring lines.
- **The second** breast line and all subsequent lines can be retrieved in the process outlined in APPENDIX J.

The ship should never retrieve a messenger line, a heaving line, or a mooring line using the ship's winches while jetty crew are on the dolphin. Ship's crews are requested to check that the jetty mooring crew is standing well clear before retrieving any line using a winch. This is to avoid any potential for a parted line to recoil and strike members of the jetty crew. Delays to mooring operations will occur if this process is not followed.

### 5.8.7 Excessive Mooring Line Tensions

All mooring hook loads are monitored in the terminal and tanker CCR's using an iPad supplied to the ship. All efforts must be made to keep average loads on each mooring line between 5 and 30 tonnes.

The shipboard monitor will indicate a pre-alarm condition if any mooring exceeds a load of 30 tonnes and a further alarm will be initiated if loads exceed 40 tonnes.

Instantaneous loads above 55 tonnes indicate efforts to maintain mooring line tensions below 30 tonnes have failed and, therefore, the following actions are required.

**Table 9: Actions to Manage Excessive Mooring Line Tensions**

	Role	Action
1.	Tanker crew	Alert the Pilot/Loadmaster if line tension management is becoming difficult.
2.	Pilot/Loadmaster	Call standby tugs out to assist.
3.	Pilot/Loadmaster	Advise the Duty Pilot and request assistance with managing situation, particularly with hazard management, logistics, and notifications.
4.	Pilot/Loadmaster	Stop loading, liquid free the loading arms, and prepare the arms for disconnection. Disconnection of loading arms must proceed urgently if instantaneous mooring line tensions exceeding 60 tonnes are occurring.

Woodside Port Operations will continue to assess the situation in consultation with the terminal and vessel's Master before deciding on further actions, which could include sailing the vessel.

### **5.8.8 Mooring Line Failure**

The Pilot/Loadmaster should be called immediately upon failure of any component of the mooring system. The Pilot/Loadmaster will address the following issues:

- Cease liquid hydrocarbon transfer
- Call out standby tugs to push up
- Report the event to the terminal and Duty Pilot
- Plan recovery action with the terminal and Tanker Master
- Restore mooring integrity
- Recover damaged mooring components on board, if possible
- Investigate and report.

### **5.8.9 Limiting Conditions Alongside**

During periods of long low waves or cyclonic activity, reference is to be made to the Woodside cyclone procedures, which might require the tanker to depart prior to the onset of operational limiting conditions affecting the berth. If limiting conditions become an issue while a vessel is alongside a berth, then Woodside Port Operations will assess the situation in consultation with the terminal and vessel's Master before deciding on further actions, which could include sailing the vessel.

### **5.8.10 Early Departure Guidance For Membrane LNG Tankers:**

Unforeseen circumstances such as unfavourable environmental conditions, ship or shore-based emergencies or mechanical issues may require cargo to be stopped and the vessel depart the berth partly loaded. This may leave a membrane tanker at risk of cargo tank levels being outside the critical sloshing limits. These limits are commonly between 10% and 70% of cargo tank volumes.

In this case the vessel should follow the guidance in their operating manuals and/or computer-based systems to consolidate cargo by internal transfer to attain cargo levels within the sloshing limit parameters. The vessel's Master and terminal representative will liaise as to the best and most efficient process and establish the time frame required.

The vessel may have to consider cargo consolidation in sheltered waters if this cannot be completed before departing the berth.

### **5.8.11 Loading Arm Wind Limitations**

The loading arms are rated for operation in winds of up to 50 knots. However, if winds of over 35 knots (10-metre/10-minute average) are forecast, loading is to be stopped and the loading arms disconnected before this occurs. Usually, in squall conditions, the vessel will remain alongside with arms connected.

### **5.8.12 Electrical Storms**

When there is electrical storm activity in the vicinity, loading operations are to be stopped.

## 6. SAFETY PRECAUTIONS

A Loadmaster is assigned to the tanker throughout the vessel's stay in port and will liaise between the ship and shore, particularly in the event of an emergency.

### 6.1 Cargo Handling Philosophy

The Master is responsible for the operation of their tanker including the cargo handling operation. They are to ensure their staff, who are delegated the responsibility of conducting or overseeing cargo operations and related duties, are qualified and competent to do so. At all times, sufficient personnel should be available on board to keep an efficient deck and cargo watch. In general, a Responsible Officer should remain in the cargo control room to ensure the ship/shore liaison is continuously maintained.

#### 6.1.1 Loss of Containment

The Terminal/Pilot/Loadmaster must be notified immediately of any loss of containment.

Any uncontrolled release/escape of liquid and or gas requires immediate remedial action, with steps taken dependent upon the circumstances and severity.

The Terminal/Pilot/Loadmaster will assess the leak and manage following Woodside's [Health Safety and Environment Event Reporting and Investigation Procedure](#).

### 6.2 Medical Advice

It is critical that anyone affected by a cryogenic burn must **immediately** contact the medics at the KGP front gate. They will then enact the protocols for treatment.

### 6.3 Ship/Shore Communications

ALL SHIP/SHORE MESSAGES MUST BE READ BACK TO ENSURE CONCISE COMMUNICATION. ONLY AGREED TERMINOLOGY MUST BE USED.

During critical periods of the operation, such as "start up" and "topping off", the Pilot will be in the tanker's CCR to monitor operations and will assist in communications where necessary. The tanker is to inform the Pilot of any circumstance that can affect normal loading operations.

#### 6.3.1 VHF/UHF Radio Link

The standby tugs will maintain a continuous watch on VHF Channel 82. The tanker CCR is required to continuously monitor this channel which is dedicated to the terminal operation.

### 6.4 Emergency Documents

Before commencing operations, the Master or his deputy must ensure that copies of the following documents are placed ashore at the head of the gangway:

- Cargo handling plan
- List of characteristics of cargo on board and to be loaded, together with the position of stowage
- Crew list
- Vessel's general arrangement plan
- Vessel's fire plan.

### 6.4.1 Ship/Shore Safety Check List

The ship/shore safety inspection will be conducted jointly by the Pilot on behalf of the terminal and the Chief Officer, or their appointed representative, on behalf of the tanker. The safety checklist, as contained in the "Port Document", will be completed and signed by the parties prior to the opening of the tanker's manifold valves. Repetitive checks will be carried out as necessary, but at least every 12 hours, and must be initialled with the time of the check to indicate continued compliance.

## 6.5 Vessel Readiness

The Master of the vessel should ensure that their vessel is always securely moored alongside. All mooring winches are to "out of gear and on the brake".

There must be sufficient crew members, with responsible officer supervision, always on board to deal with any emergency. At least one member of the duty watch must always be visible on deck.

### 6.5.1 Main Engine Readiness

While alongside the terminal, the tanker's main engines and related auxiliaries must be kept in a state of readiness such that the tanker can leave under her own power in an emergency.

### 6.5.2 Minor Shipboard Repairs

While alongside the terminal, repairs and maintenance to tanker machinery and equipment must be limited to those items which do not impair the:

- fire detection or fire-fighting capability of the vessel
- safe and efficient handling of cargo
- propulsive power or manoeuvrability of the tanker
- safe operation and integrity of the mooring system
- safe operation of electrical equipment located in gas dangerous zones.

"HOT WORK" in non-approved areas and work on open decks or on the jetty head, which involves hammering, chipping, or use of power tools, is strictly prohibited.

## 6.6 Fire Prevention

Sources of ignition, inclusive of smoking, must be restricted to designated areas on board the tanker and ashore. Such areas must not have direct communication with hydrocarbon dangerous zones and be ventilated on the over pressurisation and total recirculation principal.

Smoking on board is only allowed in "public" rooms as agreed between the Pilot and the Master or his deputy.

Certified safe type permanent electrical equipment must be in good order and maintained and operated in such condition that its original certification is not jeopardised.

All portable electrical equipment, including handheld torches, radios, and gas analysers, which are operated in gas dangerous zones, must be certified safe by a recognised authority for use in the flammable atmosphere concerned. All equipment should be in such a condition and operated in such a manner that its original certification is not jeopardised.

All doors, portholes, and openings from the outer deck to accommodation or machinery spaces (other than the pumproom) must be kept closed except for entry/exit purposes. All ventilators through which gas can enter must be closed and mechanical ventilation must be stopped if gas is being drawn into the system. Window type air conditioning units must not be used.

Normal air conditioning or mechanical ventilation must be used in a mode that maintains a positive pressure sufficient to prevent the ingress of any hydrocarbon gas through doors, ports, or hatches that are not gas tight or monitored by gas detectors.

All main radio equipment must be isolated and earthed while berthed at the terminal.

Use of Satcom equipment using geostationary satellites is permitted but must be switched off in the event of emergency, release of gas, or on the advice of the Pilot.

Mobile phones are not to be used outside the confines of the accommodation at any time.

During cargo handling operations, no vessel will be allowed alongside the tanker unless authorised by the Pilot and agreed to by the Master.

## **6.7 Fire Fighting Equipment**

### **6.7.1 Tanker**

All firefighting equipment must be in good working order. Portable equipment must be correctly positioned and ready for immediate use. The fire main is to be pressurised while the vessel is alongside.

The ship/shore international connection must be prominently identified with the connecting flange and bolts ready for immediate use on both tanker and shore.

Emergency towing wires are not required.

### **6.7.2 Terminal**

Prior to the tanker's arrival, the terminal will ensure that all fixed firefighting installations are in good working order, portable equipment in position, and all equipment is ready for use.

### **6.7.3 Environmental Pollution**

The Port of Dampier is in an environmentally sensitive locality as designated by the Government of Western Australia, [Department of Fisheries](#). The ecosystem within the port is vital to the ecology of the area.

All safeguards must be taken to prevent pollution of the port. Without limitation, the following points must be observed while the tanker is within port limits. Masters must ensure that their crews are aware of the anti-pollution requirements of the port.

### **6.7.4 Avoidance of Pollution**

As part of avoiding pollution:

- Any pollution by the tanker must be reported immediately to the Pilot/Loadmaster and terminal CCR. Immediate steps to stop the cause and limit the extent must be taken and the tanker's oil spill emergency plan put into operation.
- Bunker transfers alongside the terminal are prohibited except if required for hull stresses and trim purposes. Prior to any transfer, the approval of the Pilot is required. Any transfer must be adequately planned, and sufficient personnel deployed, to guard against accidental overflows and spills.
- No refuse, oily waste, or other matter likely to cause pollution is to be jettisoned from the tanker.
- Bilges and other spaces likely to be contaminated with oil residue, etc., must not be pumped into the sea.
- Contaminated ballast must not be discharged into the sea.

- Loading arms must be drained before disconnecting. Drip trays are to be placed at manifolds to collect any drips or spillage. Suitable absorbent material should also be on hand.
- During operations, the scuppers of all vessels must be effectively plugged and no leakage or spillage on board is to be swept or allowed to leak overboard. **Any leakage or spillage** must be reported immediately to the Terminal Operator, who will initiate the *Terminal Oil Spill Contingency Plan*.
- When `topping off`, ensure that the loading rate is reduced in good time and the terminal is “standing by” to “stop loading”, as required.
- **Never** rely on a “shore stop”. It will not absolve the vessel from blame, or any clean up expense, if the cargo tanks overflow.
- Always ensure that the valves of a shut off tank are not leaking. Check the ullage of the “shut off” tank” shortly after the valve has been closed. When topping off the final tank, make sure that the loading rate is eased down, and the shore personnel are on standby to shut off.
- All flanged joints required to connect loading arms to a vessel (e.g. reducing pieces/spools) must contain “full bolting” using the largest possible bolts to fit the flange holes.
- All overboard discharge/sea valves part of, or connected to, the cargo oil system must be shut, lashed, and sealed during the loading operations, to prevent any accidental discharge of oil through the pump room or engine room.
- Prior to commencing any loading operation, the Loadmaster must confirm with both the vessel and the surveyors that all overboard discharge valves on lines that could contain oil or oily fluid in the pumproom and engine room are closed and sealed.

## 6.8 Manifold Access

Normal port practice always limits manifold access when the loading arms are being manoeuvred and when product is being transferred through them.

Designated personnel, who are aware of the specific hazards around the manifold area, are always permitted entry for essential reasons associated with managing the cargo transfer operation and the connection and disconnection of the loading arms. Time spent at the manifold when the arms are filling or are full of liquid should be minimised under this requirement. This hazard and the management of it will be discussed specifically at the pre-load meeting on board the tanker prior to each cargo transfer.

Any purging activity performed by terminal or ship staff can lead to peak noise levels. All personal at manifold should be aware that a purge is about to occur, so they can fit hearing protection.

## 6.9 Accommodation Access

The Pluto Gas Plant (PGP) is a highly secure facility with strictly controlled jetty access in accordance with Australian Federal Government legislation.

Vessels at Maritime Security (MARSEC) Level 1 must keep accommodation block access doors closed but not locked. Pilots, Loadmasters, and Surveyors attending LNG vessels require access to the accommodation block through the main/upper deck entrance doors.

## **7. SERVICES**

### **7.1 Fuel**

Bunker fuel or diesel fuel is not available at the terminal.

### **7.2 Refuse**

No garbage, rubbish, or refuse can be thrown overboard while the vessel is within the berth limits. The Master can make special arrangements with the Agent and Government authorities for removal and disposal during an extended stay.

### **7.3 Fresh Water**

Not available

### **7.4 Stores and Provisions**

Subject to prior approval, a small amount, one pallet of hand carried items, can be provided. For larger orders, Masters are recommended to cable their Agents giving seven days' notice of their requirements. Large quantities of ships stores cannot be loaded at the berth and boat/barge transportation to the anchorages will be required.

### **7.5 Repairs**

Minor ship repair work can be arranged through the ship's Agent. No repairs or engine immobilisation can be undertaken at the berth.

### **7.6 Customs**

A sub collector of Customs and staff are resident in the area.

### **7.7 Police**

There are police stations in Dampier and Karratha.

### **7.8 Security**

All personnel wishing to enter or leave Pluto Terminal facilities must be cleared through the plant security gates, where they will be checked against a crew or visitor list provided by the ship's Agent.

### **7.9 Air Communications**

The area is served by frequent daily air services to Perth and other cities. The service operates from Karratha airport situated approximately 15 kilometres from the terminal.

### **7.10 Medical Assistance**

Doctors and dentists are available in Karratha and Dampier. A modern hospital is situated in Karratha. Very seriously ill patients can be transferred to Perth by the Royal Flying Doctor Service.

## 7.1 GENERAL RESPONSIBILITIES

### 7.1.1 Pilotage

Woodside Pilots are expected to ensure any pilotage operation undertaken within the Port of Dampier and at offshore facilities are carried out in accordance with the requirements of the Port Operations sub process, local procedures, standards, and instructions, and with due regard to good seamanship.

### 7.1.2 Terminal Representative/Loadmaster

Woodside Pilots acting as Loadmaster are expected to act as the Terminal Representative and ensure that any tanker conducting cargo operations carries out these activities in compliance with Port Operations procedures, relevant terminal handbooks, and local facility procedures.

The Terminal Representative will:

- provide an emergency response focal point
- carry out joint safety rounds with the ship's crew
- coordinate the starting and finishing of cargo
- attend the vessel's cargo control room during critical activities
- coordinate with stakeholders the timings involved with the cargo operations, berthing, and sailing of the vessel
- provide general liaison with the terminal over cargo matters
- coordinate commercial issues between the ship and the terminal.

The Terminal Representative role is seen by many stakeholders as the focal point for the individual ship visit and thus the person to call for any issue with the vessel. However, while the Terminal Representative should endeavour to ensure a smooth ship's visit for all stakeholders, the Pilot is **not** expected to be on call to deal with the following:

- Ship Agent's communication with the Master
- Issues with the crew and access through the facility
- Ship's stores.

The Pilot should ensure that, after the cargo has settled down, ship's staff and the terminal should call them only for safety and cargo critical issues and not general ship-related activities. The coordination of commercial matters has the potential to interfere with the ability of the Pilot to get quality rest to adhere to the plan for managing the ship's visit. The Pilot should call for relief if commercial matters have disrupted the ship's visit plan in terms of the assigned Pilot's fatigue management.

Pilots are encouraged to switch off their mobile phone to rest and leave instructions for the ship's crew to call them if required for Loadmaster responsibilities.

The Senior Pilot is encouraged to divert his mobile phone to pilots not currently assigned a tanker, so that they can get quality rest breaks.

## 8. CONTACTS

### 8.1 Woodside Contacts

**Table 10: Woodside Contact Details**

Entity	Contact Type	Details
--------	--------------	---------

This document is protected by copyright. No part of this document may be reproduced, adapted, transmitted, or stored in any form by any process (electronic or otherwise) without the specific written consent of Woodside. All rights are reserved.

Controlled Ref No: XA7500MW0001

Revision: 23

Native file No: 5221942

Page 36 of 73

Uncontrolled when printed. Refer to electronic version for most up to date information.

Woodside Energy Limited	Address	PO Box 517 Karratha WA 6714
	Phone	(61) 8 9183 8118
	Main Gate Radio Room	(61) 8 9158 8171
Woodside Marine Pilotage Operations	Phone	(61) 8 9158 7076
	Duty Pilot mobile	(61) 438 993 420
	Email	<a href="mailto:pilotloadingmaster@woodside.com.au">pilotloadingmaster@woodside.com.au</a>

## 8.2 Pilbara Ports Operations

**Table 11: Pilbara Ports Operations Contact Details**

Contact Type	Details
Contact	Harbour Master Pilbara Ports Authority
Address	PO Box 285 Dampier WA 6713
Phone	(61) 8 9158 6562 (Harbour Master)
Fax	(61) 8 9159 6558
Port Communications (VTS)	(61) 8 9158 6556

## 8.3 Shipping Agencies

**Table 12: Shipping Agencies Contact Details**

Entity	Contact Type	Details
GAC Australia, Dampier Office	Address	Unit 6, 18 Hedland Place Karratha, WA 6714 Australia
	Phone	+61 8 9183 8627
	Fax	+61 8 9185 1251
	Email	<a href="mailto:shipping.dampier@gac.com">shipping.dampier@gac.com</a>
	Website	<a href="http://www.gac.com">www.gac.com</a>
Five Star Bulk Shipping Pty Ltd	Address	PO Box 11 Karratha WA 6714 Australia
	Phone	+61 8 91838627
	Fax	+61 8 91851251
	Email	<a href="mailto:dampier@vstarcosco.com.au">dampier@vstarcosco.com.au</a>
Inchcape Shipping Services Pty Ltd	Address	Unit 7, Lot 6/20 Hedland Place 2nd Floor Building Society House Karratha WA 6714 Australia
	Phone	(61) 8 9185 6319
	Fax	(61) 8 9185 2971
	Email	<a href="mailto:dampier@iss-shipping.com">dampier@iss-shipping.com</a>

Entity	Contact Type	Details
Monson Shipping Agency Pty Ltd	Address	185/26 Sharpe Ave (PO BOX 939) Pegs Creek WA 6714 Australia
	Phone	+61 8 9197 2555
	Fax	+61 8 6270 4450
	Email	<a href="mailto:karratha@monson.com.au">karratha@monson.com.au</a>
Wilhelmsen Port Services Pty Ltd	Address	Unit 4 and 5 Balmoral Centre Balmoral Road PO Box 1005 Karratha WA 6714 Australia
	Phone	+ 61 8 9144 2311
	Fax	+ 61 8 9144 2008
	Email	<a href="mailto:WSS.dampier@wilhelmsen.com">WSS.dampier@wilhelmsen.com</a>

## 9. LNG LOADING FACILITIES

### 9.1 LNG Carrier Particulars

As a general condition for all LNG carriers at the terminal, it is required that the vessel complies with the following listed in Table 13.

**Table 13: LNG Carrier Particulars**

Area	Requirements
Equipment	All equipment must be in a sound state of repair, with main engines, mooring winches and windlasses all in proper working order. Mooring equipment, including mooring lines, must be in good condition.
Certification	All LNG carriers must be in possession of a complete and valid set of safety certificates. These include: <ul style="list-style-type: none"> <li>• Certificate of Fitness for the carriage of liquefied gases in bulk</li> <li>• Load Line Certificate</li> <li>• Safety Construction Certificate</li> <li>• Safety Radio Certificate</li> <li>• Cargo Equipment Register</li> <li>• Safety Equipment Certificate</li> <li>• Cargo Gear Certificates</li> <li>• ISM Safety Management Certificate</li> <li>• ISSC.</li> </ul> Vessels are to be in all respects "In Class".

### 9.2 LNG Communication System

Pluto CCR is operated remotely through a fibre optic link from the Woodside headquarters in Perth.

The following communication systems must be used for operational requirements:

- Terminal-supplied UHF (portable) link for cargo operations between the tanker and the terminal CCR.

- A VHF link as backup to the UHF.
- Private Automatic Branch Exchange (PABX) phone handset (no extension required, lift-to-ring) direct to the terminal CCR through the fibre optic link or electrical link in the case of a condensate vessel.

The terminal will supply intrinsically safe portable handsets when required.

### 9.3 LNG Venting

Boil off gas must not be vented to atmosphere under normal cargo loading operations.

In the event of vapour return compressors being inoperative due to mechanical breakdown, the terminal CCR is to be informed and loading stopped immediately. Where this condition makes it imperative to vent boil-off gas to atmosphere, every endeavour must be made to heat the gas prior to its discharge to ensure its relative density is as low as possible.

The burning of gas for engine room requirements is permitted where commercial and statutory requirements are followed.

### 9.4 LNG Tanker ESD System

Cargo operations are safeguarded by an emergency shutdown (ESD) system. This system operates through a fibre optic link and is backed up by an electric or pneumatic system in case of breakdown.

### 9.5 Pre-Loading Operations

#### 9.5.1 Fitting of Gangway

On completion of mooring, the Pilot will advise the Terminal Operator that the tanker is secure and the gangway can be lifted aboard.

The gangway is hydraulically operated and sits on the tanker's strengthened rail. A responsible member of the tanker's staff, nominated by the Master, should be standing by on board to assist in the placement of the gangway. The Terminal Operator and tanker's staff member are to inspect and agree that the gangway and associated safety equipment are in place and secured prior to allowing personnel access to the gangway.

#### 9.5.2 Pre-Loading Meeting

Prior to the commencement of liquid loading arm connection, a pre-load meeting must take place. The meeting will include the tanker's Chief Officer, the Pilot, and a suitably briefed representative of the LNG Plant.

The meeting agenda will include the items as listed in the *LNG Tanker Port Document LNG Loading Plan* and the shore interface elements of the *Ship Shore Safety Checklist*. The final quantity to be loaded will be noted, with instruction coming from the latest *LNG Information Sheet* or LNG Offtake Coordinator (OTC).

The objective is to ensure operations are conducted in a safe, environmentally friendly, and efficient manner.

### 9.6 Configuration and Limits of Loading Arms

#### 9.6.1 QC/DC

The loading arms are equipped with a quick connect (QC)/disconnect coupler (DC).

## 9.6.2 Configuration

The terminal is fitted with four loading arms.

- Two outer arms, A and D, are LNG loading.
- Two inner arms, B and C, are LNG loading and vapour return arms (A is closest to shore).

The normal loading arm configuration will be either arms:

- A (L) / B (V) / C (L); or
- B (L) / C (V) / D (L).

If, due to maintenance considerations, either B or C arms are unavailable, the two outer arms can be used (A and D). The ESD envelope will be reduced due to this alignment. The position of the "Spotting Line" will be determined by the terminal and is dependent on the vapour return arm (B or C) to be used.

Should an LNG loading arm become inoperable during loading, (e.g. due to a valve malfunction or leak), an early decision as to whether to change the line-up could save considerable time. Such a malfunction is likely to be noticed at the start of loading, although a significant leak can occur at any time during loading.

It is possible to continue to load using one arm, with a maximum rate of 5,600 m<sup>3</sup>/hr for the whole or balance of loading.

### 9.6.2.1 Loading Arm Limits

See APPENDIX F and APPENDIX G for information on loading arm limits.

### 9.6.2.2 Weather Limitations

The loading arms are designed to be manoeuvred in wind speeds of up to 50 knots. Loading should be stopped, and arms disconnected, parked, and storm/cyclone locked in good time if wind speeds more than 35 knots are anticipated.

### 9.6.2.3 Fitting of Short Distance Pieces and Strainers to Ship's Loading and Vapour Lines

The vessel must present at the Pluto Terminal with its "short distance pieces" (see APPENDIX L) fitted to its liquid loading and vapour return manifolds as nominated by the terminal. A 60-mesh cargo manifold loading strainer (or dual flow strainer) is to be installed within each of the nominated loading lines and a strainer in the range of 20 to 60 mesh (or dual flow strainer) is to be installed within the nominated vapour return line. For avoidance of doubt, this applies every time the vessel connects to carry out either a gas up, cooldown, or loading operation at the Pluto Terminal.

**Note:** Where a strainer is found to be damaged prior to arm connection, the loading is to be delayed until the strainer is replaced.

### 9.6.2.4 Connection of Loading Arms

While the loadings arms are unattached and being manoeuvred in the manifold area, all ship's staff are to remain clear of the arm by a radius of 1.5 m, to avoid contact and the risk of crushing injury. Permission to enter this radius including to approach ships presentation flange must be granted by the shore personnel.

The vapour return will be connected first, followed by the liquid arms.

The tanker will be responsible for arriving with the "short distance spool pieces" (if so equipped) and loading strainers in place and removing the tanker's manifold blank flanges.

Following connection for all loadings, including gas up and tank cooldowns, the loading arms will be pressure tested to 600 kPa and the vapour line to 200 kPa gauge and inerted to <1% oxygen.

The Loadmaster will be satisfied that the above tests have been satisfactorily completed before any tanker ESD valves can be opened.

### **9.6.3 Water Spray System**

Prior to opening the tanker's manifold valves, the tanker's side water curtain, in way of the manifold, must be brought into operation by the tanker's personnel.

All other required protection systems in way of tank domes, flanges, valves, and superstructure, as required, must be operable.

### **9.6.4 Measurement of Cargo Heel**

Prior to the opening of the tanker's manifold valves, the quantity of cargo heel is to be measured. This applies in all cases, regardless of whether the tanker requires gas up, full or partial cooldown, or normal loading.

The measurement is to be witnessed by the tanker's Designated Officer on behalf of the tanker, and by the Pilot on behalf of the terminal. If an independent cargo surveyor has been appointed, they should also witness the custody transfer measurement.

The initial measurement is subject to any special requirements for heel measurement on completion of cooldown after a refit or gas up.

### **9.6.5 Testing the ESD System**

#### **9.6.5.1 Routine Testing**

Many of the ESD system checks are conducted by the terminal on a routine basis without a tanker in the berth. However, the ESD1 system will be tested for each loading as shown in the following sections.

#### **9.6.5.2 Prior to Arm Cooldown**

After advising the terminal CCR, the tanker will initiate an ESD1 logic test from the tanker through the ESD FOSSL. For this test, ESD valves ashore and on board the tanker should remain closed.

When the terminal and tanker are ready to commence loading, the ESD valves ashore and on board the tanker are to be opened. The terminal will initiate an ESD1 from ashore. The total closure time of the tanker's ESD valves is to be timed and witnessed for correct operation.

#### **9.6.5.3 When the Loading Arms are Cold**

During the final stages of ship line cooldown and prior to ramping up the loading rate, the operation of the tanker's manifold ESD valves must be tested. This test will be conducted by ceasing liquid flow in one loading arm, while maintaining the liquid flow in the other loading arm.

When all parties are ready, the Pilot will request the terminal to cease the liquid flow in the appropriate loading arm, and this will be confirmed by the terminal. When this is done, the tanker will manually close (stroke) the manifold ESD valve on that liquid line. This will be witnessed for correct operation and, when satisfied, the Pilot/Loadmaster will request the tanker to re-open the ESD valve and the terminal to resume liquid flow when the valve is opened. This will then be repeated for the other liquid line.

#### 9.6.5.4 Cold ESD1 Test

On occasions it is necessary to carry out a Cold ESD test.

After drydocking or interventive maintenance work has been completed on ESD valves, a Cold ESD test of the connected liquid and ESD valves can be conducted at the tanker's request.

Valves will be shut by activating an ESD1 from the shore as a test of the ESD1 system with valves cold. Both the tanker ESD1 valves and shore hydraulic ESD1 valves will be witnessed for correct operation.

Prior to the initiation of any test, the liquid flow through the loading arms will be stopped.

The Pilot/Loadmaster must ensure that both the ship and terminal personnel are fully prepared and that all personnel near the manifold move to a safe location.

When the Pilot is completely satisfied that all necessary precautions have been observed and agreement has been obtained from both parties, the ESD1 test can proceed.

The ESD1 activation must be preceded by a countdown, which is to be undertaken by the party initiating the test.

### 9.7 Cargo Handling

The Pluto Terminal operates under strict environmental emission conditions. Close cooperation between the loading vessel and the terminal is necessary to comply with these conditions.

The terminal must keep the tanker informed when loading pumps are stopped, started, or when a loading line up or rate is changed.

The tanker will keep the terminal informed of any changes in the tanker's gas up, cooldown, or loading cargo line-up, and the starting and stopping of return gas compressors. Tanker is to ensure that liquid or vapour flows to the vessel are never blocked off by having insufficient tanks open and valves excessively choked.

#### 9.7.1 Normal Loading

On completion of the loading arms purge and pressure tests, the tanker's Designated Officer, the Pilot, and the terminal CCR must agree all systems are correctly lined up and ready. The tanker's vapour return manifold can then be opened, and tank pressure returned ashore through free flow or high duty compressor, if required.

#### 9.7.2 Vessel Exclusion Zone

During loading operations an exclusion zone of 180 metres exists around the starboard manifold while bulk rate liquid transfer is underway (see APPENDIX A). Storing vessels are not allowed to enter the exclusion zone while any liquid is in the loading arm.

#### 9.7.3 Inerted Condition

When a tanker arrives in an inerted condition, the vapour return line is lined up to the shore flare until the gassing up of the tanker's tanks and pipeline systems has been completed. Before gassing up, the tanker will be fitted with a strainer at the vapour return manifold (shore supply).

#### 9.7.4 Cooldown and Gassing Up

##### 9.7.4.1 Cooling of Loading Arms and Tanker's Pipeline System (Normal Operations)

Under normal loading operations, the tanker will arrive at the terminal with loading lines and manifold at ambient temperature.

Prior to commencing the cooldown of loading arms and tanker's pipeline system, the tanker and terminal CCR must confirm the:

- tanker is ready to accept liquid/vapour through the loading arms
- terminal is ready to commence cooldown of the loading arms.

When both parties have confirmed readiness, the tanker will request the terminal to commence cooldown. Both arms will be cooled down simultaneously by means of the cooldown controller valves.

Cooldown flow rate will be regulated to 7 m<sup>3</sup>/hr on each arm until LNG reaches the apex of the loading arms. Flow rate will be increased to 115 m<sup>3</sup>/hr on each arm from this point.

#### 9.7.4.2 Gassing Up of Cargo Tanks

(Tankers arriving in an inerted condition).

The line up and cooldown of the tanker's loading lines will be in accordance with the normal cooldown procedure, except that only one loading arm will be required to be cooled at this stage. The tanker will specify to the terminal the liquid flow required.

Gassing up of the tanker's tanks will be by displacement. LNG liquid is taken through the cooldown lines and through the LNG vaporiser to the vessel's tanks, as vapour, through the vapour line into the top of the tanks. The inerted vapour is displaced through the liquid line, temporary elbow, and HD compressor to the shore flare. To reduce flaring ashore, each cargo tank is isolated when gassed up. Towards the end of the gassing up operation there will be short periods where the makeup of the vapour return will rapidly change from inert gas to LNG vapour and back to inert gas as the tanker gasses up the pipeline system. Consistent LNG vapour return will not occur until the end of the operation.

The tanker will keep the terminal informed regarding the status of the gassing up operation, using onboard sampling (hydrocarbon content).

To complete the "Gas Up" a small amount of C1 gas venting will take place, to purge the dead legs. This will occur if a vessel is to proceed to "Tank Cooldown". The venting can interact with the jetty fire and gas system, potentially causing an ESD1.

#### 9.7.4.3 Cooldown of Tanker's Cargo Tanks

After gassing up the tanker's tanks and pipeline system, cooldown of the tanker's spray pipework can be commenced. After this is completed, the tanker will request adjustments of the liquid flow rate to cool down the cargo tanks.

At the completion of cooldown of the tanker's tanks, the second loading arm will be cooled down. When both liquid arms and the vessel's ESD valves are cold, liquid flow will be stopped and an ESD1 test conducted. Loading can now commence.

From time to time, the terminal can require an adjustment in cooldown rate to meet environmental flaring requirements.

Maximum cooldown rate for ship cargo tanks is 167 m<sup>3</sup>/hr.

#### 9.7.5 Loading and Topping Off

All loading activities will be at the discretion of the tanker. The terminal CCR might require stopping loading at any time due to terminal operational requirements.

The terminal is responsible for measuring the pressure differentials across the strainers fitted in the shore system. Any abnormal change in the differential pressure indicating a blockage or failure of

any strainer is a potentially serious matter and loading is to be suspended through both arms until the cause is ascertained and rectified. Pressure comparisons between ship and shore commence at the start of ramp up, with every rate change, and continue hourly (when loading at full rate) until ramp down commences.

Every hour during the loading, the tanker is to inform the terminal of the quantity received, loading rate, expected ramp down time, and manifold pressures on liquid arms.

In the event of a trip of the loading pumps, the terminal must not resume loading until the tanker has confirmed loading can recommence.

Throughout the loading operation, the tanker must provide reasonable notice to the terminal for any changes or requirements which affect the loading operation. This is especially critical during topping off sequences. In the initial stages of loading, the tanker and shore will monitor the rate of loading such that the need to flare excess return gas is minimised.

**9.7.5.1 Cargo Ramp-Up**

This will be at the tanker’s request, at intervals of 1000 m³/hr. Proper attention to communication procedure is essential for a smooth operation at this time.

**9.7.5.2 Ramp-Down and Topping Off**

Ramp down of shore cargo pumps is usually 60 minutes duration in 1000 m³/hr increments, with each decrease at the ship’s request to a minimum 1000 m³/hr, at which the stop loading order will be made. Topping off is to be arranged such that there is a stable period of at least 10 minutes’ pumping at 1000 m³/hr prior to calling for a stop.

It is critical that communications between the tanker and the terminal are not compromised in any way during topping off of the cargo. If there is any defect in the communications systems, tank protection, CTMS, Whessoe gauge system (as back up), or tank filling valves, the Loadmaster will direct the topping off operation to be stopped immediately.

Prepare and have a documented ramp down plan (for topping off tanks), like the example in Figure 1, available for review at the preload meeting to allow tanks to be closed in a planned, controlled sequence. **Loading will not commence until this plan is presented.**

9000	00:00	35.66	34996	94.9	-1	37.56	36013	97.7	-1	36.53	35528	96.4	-1	36.03	35229	95.6
8000	00:04	35.90	35146	95.3	-1	37.91	36163	98.1	-1	36.81	35678	96.0	-1	36.28	35379	96.0
7000	00:08	36.12	35279	95.7	-1	38.26	36296	98.5	-1	37.08	35811	97.1	-1	36.52	35512	96.3
VL300	00:12	36.33	35396	96.0		38.59	36413	VL300	-1	37.32	35928	97.5	-1	36.74	35629	96.6
6000	00:16	36.61	35552	96.4					-1	37.67	36084	97.9	-1	37.04	35785	97.1
5000	00:20	36.86	35685	96.8					-1	38.00	36217	98.2	-1	37.32	35918	97.4
4000	00:24	37.08	35796	97.1					-1	38.30	36328	98.5	-1	37.57	36029	97.7
VL200	00:28	37.26	35885	97.3						38.55	36417	VL200	-1	37.77	36118	98.0
3000	00:32	37.55	36018	97.7									-1	38.11	36251	98.3
2000	00:36	37.79	36118	98.0									-1	38.38	36351	98.6
VL100	00:40	37.95	36185	98.1										38.58	36418	VL100
1000	00:44	38.30	36318	98.1												
STOP	00:48	38.49	36365	STOP												
						0										
FINAL LEVEL		38.59	36420			38.59	36413			38.55	36417			38.58	36418	
						TTL=	145668									
																98.780%

Figure 1: Example Ramp Down Plan

### 9.7.6 Prevention of Free Flow of Liquid

To prevent free flow of liquid to the tanker at either the start or end of loading, the terminal will use the main loading control valves. These valves will be opened at the commencement of forward flow and closed when tanker requests loading to stop.

### 9.7.7 Cargo Ramp-Up and Ramp-Down

This will be at the tanker's request at intervals of 1000 m<sup>3</sup>/hr. Proper attention to communication procedure is essential for smooth operation at this time.

## 9.8 Draining and Inerting of Loading Arms

On completion of loading, the terminal liquid loading valves and tanker's liquid loading double shut valves are to be closed for MOSS vessels and ESD valves for membrane tankers.

**Note:** Tanker's valves should not be shut until the Loadmaster has confirmation that shore valves are shut.

The liquid loading arms should be drained and purged sequentially using the following procedure:

1. The loading arm will be pressurised to 600 kPa with nitrogen and then the tanker will open the manifold cooldown valves, allowing the nitrogen to displace the liquid in the shipside section of the loading arm to the vessel's cargo tanks.
2. The terminal will admit nitrogen and pressurise the loading arms to approximately 600 kPa. The shore side section of the loading arm, together with associated systems, will then be drained back ashore.
3. Upon completion of the draining of the loading arms, the arms should be purged with nitrogen until a hydrocarbon content of less than 2% by volume, or less than 40% lower explosive limit (LEL), is achieved.
4. The vapour return line will remain open to shore throughout the liquid arm draining. After the liquid arms have been drained and purged and with the mutual agreement of both the tanker and the terminal, the vapour return valves can be closed, and the vapour return arm purged with nitrogen to achieve a hydrocarbon content of less than 2%.

## 9.9 Completion of Operations

### 9.9.1 Disconnection of Loading Arms

While the loadings arms are unattached and being manoeuvred in the manifold area, all ship's staff are to remain clear of the arm by a radius of 1.5 m, to avoid contact and the risk of crushing injury. Permission to enter this radius, including to approach the ship's presentation flange, must be granted by the shore personnel.

The terminal is responsible for fitting the blanks to the terminal's liquid loading and vapour return arm flanges.

The tanker is responsible for fitting blanks to the tanker's manifold. If terminal-provided spool pieces have been used, these will be disconnected by the vessel and landed back on the jetty.

The strainers must be inspected and recorded by the Pilot or the Terminal Operator and confirmed clear of debris or damage. Any debris should be collected, and both parties given a sample for analysis.

### 9.10 Final Measurement of Cargo

The final quantity of cargo on board must be measured after all the tanker's manifold valves have been closed.

An independent surveyor can determine cargo quantity and quality.

### 9.11 Documentation

In order to secure the Master's signature, it is desirable to receive documentation on board prior to the vessel sailing. The Pilot/Loadmaster will receive documents on behalf of the terminal.

The Pluto Terminal practises early departure procedures (EDP).

### 9.12 Removal of Gangway

The gangway will be removed on confirmation of all personnel ashore. A responsible member of the tanker's staff should be standing by on board to assist if any problems emerge that might require action from the tanker. The fibre optic ship shore link (FOSSL) will be disconnected immediately prior to the lifting of the gangway.

### 9.13 Main Engine Preparation for Sailing

Procedures for preparing main engines for sailing can only be implemented after the loading and vapour return arms have been disconnected and gangway removed from the vessel.

Pre-departure testing of the main engine can only be carried out with the full agreement of the Pilot.

## 10. CONDENSATE LOADING FACILITIES

### 10.1 Condition of Condensate Tankers

As a general condition for vessels at the terminal, it is required that the vessel is acceptable to the Operator and complies with the following:

#### 1. Equipment

- a. All tankers must be in a sound state of repair, with main engines, mooring winches, and windlasses all in proper working order. Mooring equipment, including mooring lines, must be in good condition. Manifold equipment to comply *with OCIMF Recommendations for Oil Tanker Manifolds and Associated Equipment*.

- b. Certification

All tankers must be in possession of a complete and valid set of safety certificates. These are to include:

- i. Load Line Certificate
  - ii. Safety Construction Certificate
  - iii. Safety Radio Certificate
  - iv. Safety Equipment Certificate
  - v. Cargo Equipment Register
  - vi. Cargo Gear Certificates
  - vii. ISM Safety Management Certificate
  - viii. International Ship Security Certificate
- c. Vessels are to be in all respects "In Class"
  - d. Vessels must be able to comply with the following minimum loading rates:  
Vessels larger than 50,000 tonnes SDWT must be able to maintain a loading rate of the larger of 5% of vessels SDWT in TPH or 4000 TPH (approximately 5.3 MI each hour).  
Vessels less than 50,000 SDWT are required to turn around within a maximum period of 24 hours (No. 8 Beacon inward to No. 8 Beacon outwards). This provides a window of 18 hours from commencement to completion of loading.

- e. Maintain a coverage with a Protection & Indemnity (P&I) club which is a member of the International Group of P&I Clubs, for legal liability of oil pollution damage up to the current maximum amount being offered by the International Group of P&I Clubs supplemental coverage available through such P&I clubs. Current coverage of \$1 billion dollars U.S. is required.

## 10.2 Loading Rates

Maximum loading rate through two condensate loading arms is 4800 m<sup>3</sup>/hr.

## 10.3 Shore Tank Capacity

Total pumpable capacity: 119,000 m<sup>3</sup>

Tanks 1 and 2: 60,000 m<sup>3</sup> each

## 10.4 Loading Arms

There are two 12" condensate loading arms for loading condensate on the jetty.

Tankers should prepare 16" reducers on the starboard side.

### 10.4.1 Loading Arm Limits

See APPENDIX H and APPENDIX I for information on loading arm limits.

Slewing Range: 3.6 m forward of centre line. 3.6 m aft of centre line

Horizontal range: Maximum distance from fender face: 14.5 m

Vertical range: 7.1 m to 21.2 m above Chart Datum

The loading arms are designed to be manoeuvred in wind speeds of up to 50 knots. They should therefore be disconnected, parked, and storm/cyclone locked in good time if sustained wind speeds of 30 knots are anticipated (maximum allowable wind for sailing).

**Note:** Shore operators will not manoeuvre the arms in winds more than 35 knots. Particular attention should be paid to this during cyclonic events.

### 10.4.2 Connection of Loading Arms

The connection at the tanker manifold is by quick connect/disconnect couplers (QC/DC) which have been designed to adapt to tanker flanges of 12" and 16" Class ANSI 150 lb. Tankers are normally required to present a clean 16" flange with a minimum flange thickness of 36.6 mm and maximum of 39.8 mm.

**Note:** Although these areas are fitted with QC/DC couplers, the arms cannot be disconnected without operating the key interlock system. This system is not an emergency release system.

While the loadings arms are unattached and being manoeuvred in the manifold area, all ship's staff are to remain clear of the arm by a radius of 1.5 m, to avoid contact and the risk of crushing injury. Permission to enter this radius, including to approach ship's presentation flange, must be granted by the shore personnel.

Prior to removing the blind flange, the 1" drain upstream of the coupler must be opened to release any possible over pressure in the arm.

The Terminal Operator will confirm with the Pilot that the tanker's manifold is shut and that the arm pressure test can take place. The Pilot will be advised when the loading arms have been connected,

pressure tested satisfactorily, inerted, and are ready to load. The loading arms will be depressurised after the tests have been satisfactorily completed.

### **10.5 QC/DC**

The loading arms are equipped with a quick connect (QC)/disconnect coupler (DC).

### **10.6 Emergency Shut Down System**

After the gangway is secure, the Terminal Operators will place an ESD transmitter on board the tanker in the vicinity of the vessel's manifold. This is hardwired to the shore.

A logic test is conducted after the ESD transmitter is connected. Prior to commencement of loading, with at least one shore valve open and one loading pump in operation, the Pilot will test the ESD system, demonstrating its use to the ship's staff at that time.

The ESD transmitter is intrinsically safe and can be operated on deck. There is a hotline to the shore CCR as well as the ESD activation device situated in the control box.

The system is a "fail safe" facility, designed to activate loading pump shutdown and shore ESD valve closure when the shutdown button on the ESD transmitter is activated.

### **10.7 Cargo Measurement**

An independent surveyor will determine cargo quantity and quality. Custody of product will take place at ship's manifold.

The Pluto Terminal practises early departure procedures (EDP).

## REFERENCES

Title	Reference
AMSA Index of marine notices	<a href="#">Link</a>
AMSA Marine Notice 2022/12 – Requirements for the use of exhaust gas cleaning systems in Australian waters	<a href="#">Link</a>
Australian Ballast Water Management Requirements	<a href="#">Link</a>
Australian Biosecurity Act 2015	<a href="#">Link</a>
Department of Fisheries (Government of Western Australia)	<a href="#">Link</a>
GAC Australia website	<a href="#">Link</a>
Health Safety and Environment Event Reporting and Investigation Procedure	<a href="#">9905421</a>
Index or marine notices (asma.gov.au)	<a href="#">Link</a>
Local Marine Notices – Pilbara Ports Authority	<a href="#">Link</a>
OCIMF Mooring Equipment Guidelines 4th Edition (MEG4)	<a href="#">Link</a>
Pilbara Ports Authority Port of Dampier Local Marine Notices	<a href="#">Link</a>
Pluto Terminal Conditions	<a href="#">9734902</a>
Port of Dampier Handbook	<a href="#">Link</a>
WA Port Authorities Regulations 2001	<a href="#">Link</a>
Western Australian (WA) Port Authorities Act 1999	<a href="#">Link</a>
Withnell Bay Terminal Handbook	<a href="#">4089641</a>

## DEFINITIONS

Term	Meaning
Cyclone	Tropical revolving storm
Cyclone Season	Normally between November and April, but cyclones can occur any time of the year.
Hot Work	<p>Work involving sources of ignition or temperatures sufficiently high to cause the ignition of a flammable gas mixture. This includes any work requiring the use of:</p> <ul style="list-style-type: none"> <li>• welding, burning, or soldering equipment</li> <li>• blow torches</li> <li>• some power-driven tools</li> <li>• portable electrical equipment not intrinsically safe or contained within an approved explosion proof housing</li> <li>• internal combustion engines.</li> </ul>
Master	The Master of the offtake tanker unless specifically expressed.

This document is protected by copyright. No part of this document may be reproduced, adapted, transmitted, or stored in any form by any process (electronic or otherwise) without the specific written consent of Woodside. All rights are reserved.

Term	Meaning
Nautical Mile	Equivalent to 1852 metres.
Offtake Tanker	A tanker type vessel nominated to load at the terminal.
P&I Club	Protection and indemnity insurance provider.
Pilot	The Terminal Representative on board the offtake tanker responsible to the terminal for mooring and cargo operations.
Pilot Boarding Area	Nominated location within three nautical miles of the pilot boarding ground.
Responsible Officer	The person appointed by the employer or the Master of a ship and empowered to make all decisions relating to a specific task, having the necessary knowledge and experience for that purpose.
Terminal Representative	The representative on board officially assigned to represent the terminal's interests for the duration of the offtake operation from the commencement of the approach.

## ABBREVIATIONS

Abbreviation	Term
AIS	Automatic Identification System
AMSA	Australian Maritime Safety Authority
ANTT	Australian National Tide Tables
AQIS	Australian Quarantine Inspection Service
BMF	Burrup Materials Facility
BWTS	Ballast Water Treatment System
CCR	Central Control Room
DC	Disconnect Couplers
DWT	Deadweight Tonnage
EDP	Early Departure Procedures
EEZ	Economic Exclusive Zone
EPA	Environmental Protection Authority
EPBC	Environmental Protection and Biodiversity Conservation
ESD	Emergency Shutdown System
ETA	Estimated Time of Arrival
FAOP	Full Away On Passage

Abbreviation	Term
FAR	Field Auxiliary Room
FOSSL	Fibre Optic Ship Shore Link
GPS	Global Positioning System
HAT	Highest Astronomical Tide
HMPE	High Modulus Polyethylene
ISO	International Organisation for Standardisation
KBSB	King Bay Supply Base
kPa	Kilopascal
LAT	Lowest Astronomical Tide
LEL	Lower Explosive Limit
LNG	Liquefied Natural Gas
LOA	Length Overall
LPG	Liquefied Petroleum Gas
MBL	Minimum Breaking Load
MEMS	Mooring Load and Environmental Monitoring System
MHWS	Mean High Water Springs
MR	Medium Range
MT	Metric Tonnes
NM	Nautical Mile
NOR	Notice of Readiness
NWSJV	North West Shelf Joint Venture
OCIMF	Oil Companies International Marine Forum
OTC	Offtake Coordinator
P&I	Protection & Indemnity
PLP	Pluto LNG Park
PMS	Planned Maintenance System
POS	Port Operations Superintendent
PPA	Pilbara Ports Authority
QC	Quick Connect

This document is protected by copyright. No part of this document may be reproduced, adapted, transmitted, or stored in any form by any process (electronic or otherwise) without the specific written consent of Woodside. All rights are reserved.

Abbreviation	Term
ROWS	Remote Offshore Warning System
SDWT	Summer Deadweight
SMS	Safety Management System
SOLAS	Safety of Life at Sea
TPH	Tonnes Per Hour
UHF	Ultra High Frequency
UKC	Under Keel Clearance
UKSTC	United Kingdom Standard Conditions for Towage and Other Services
VHF	Very High Frequency
VTS	Vessel Traffic Service
WA	Western Australia

# APPENDIX A RECOMMENDED APPROACHES TO THE PORT OF DAMPIER

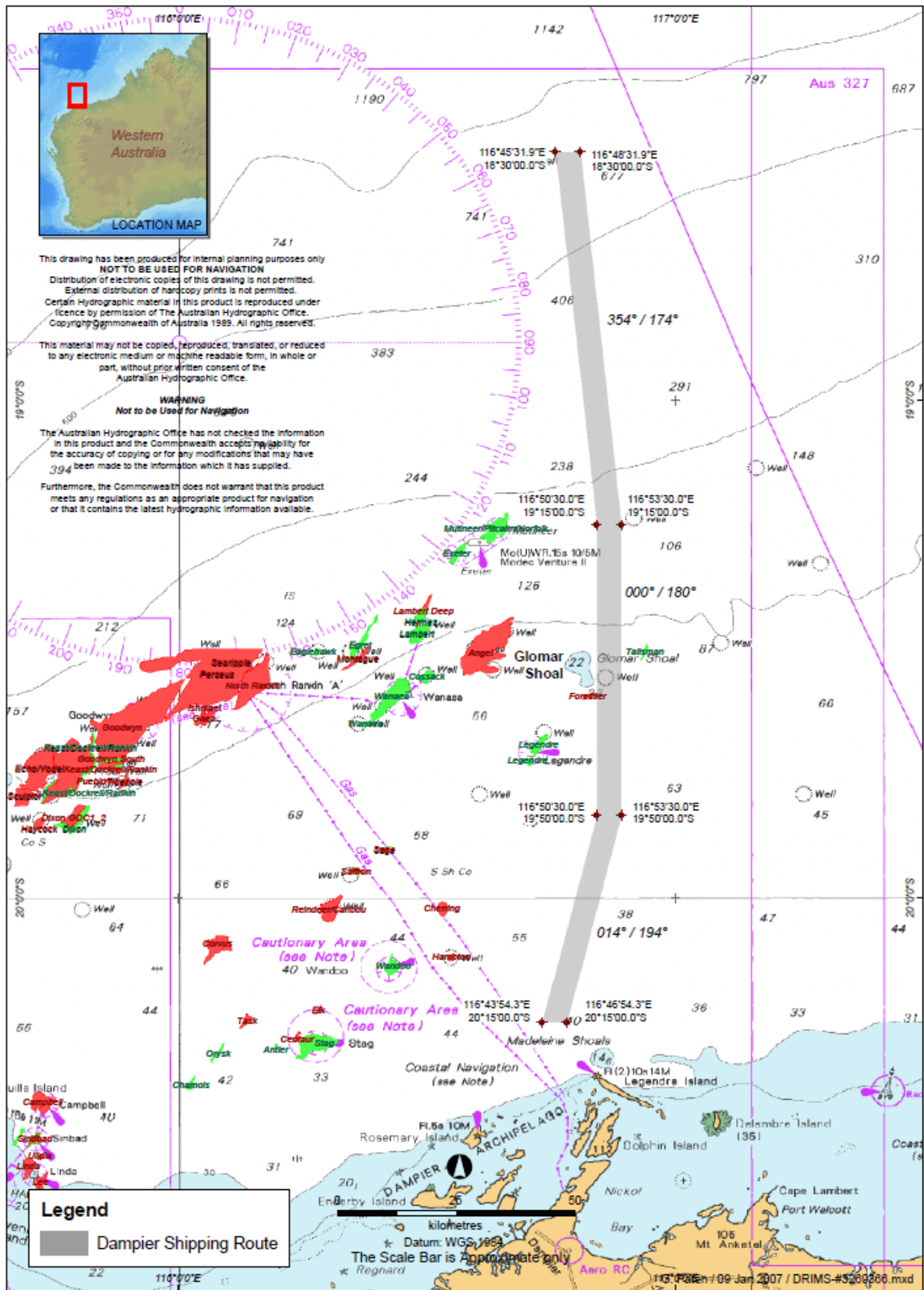

# APPENDIX B PLUTO TERMINAL

## B.1 Pluto Terminal Approaches

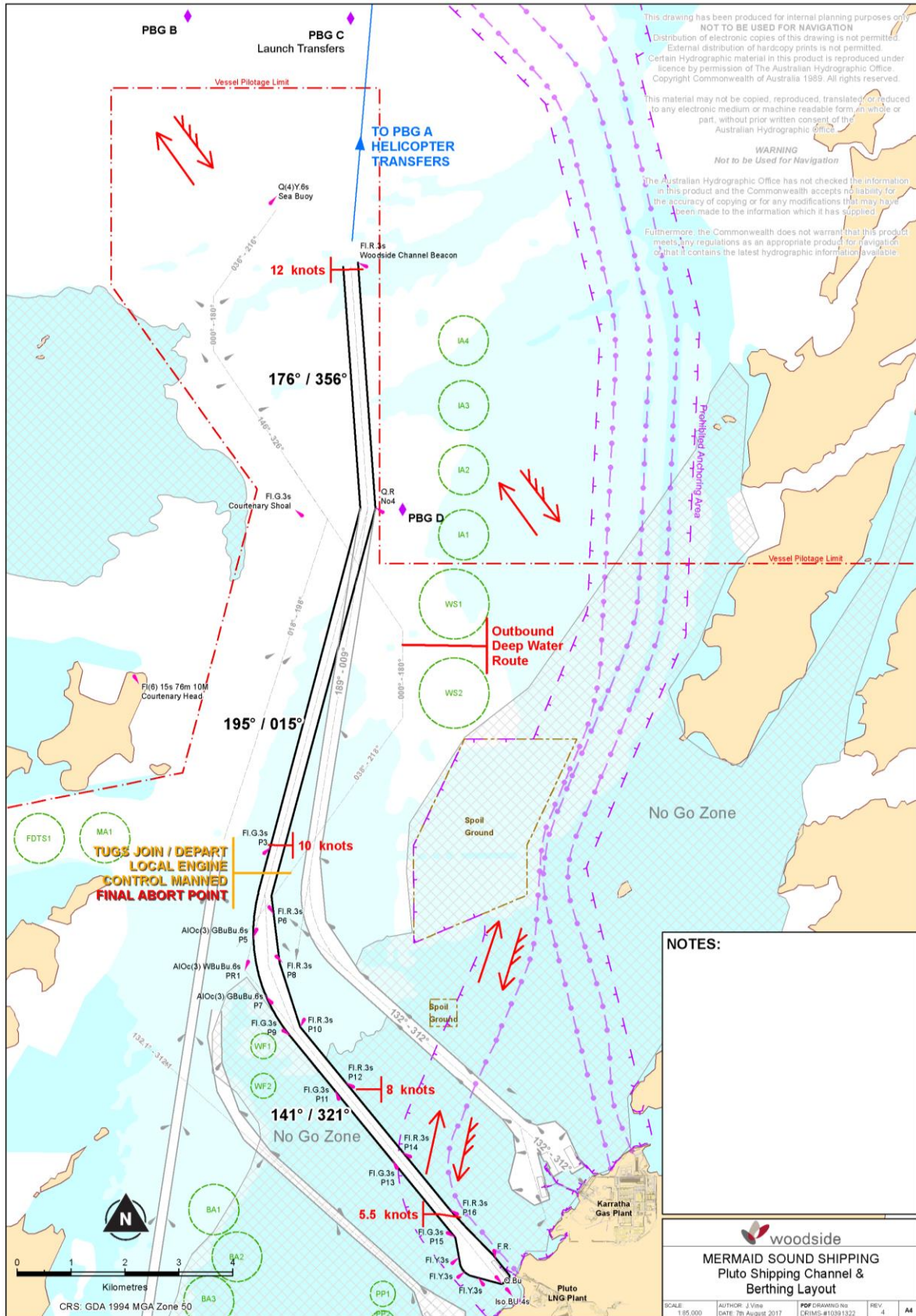

## B.2 Pluto Terminal Exclusion Zone

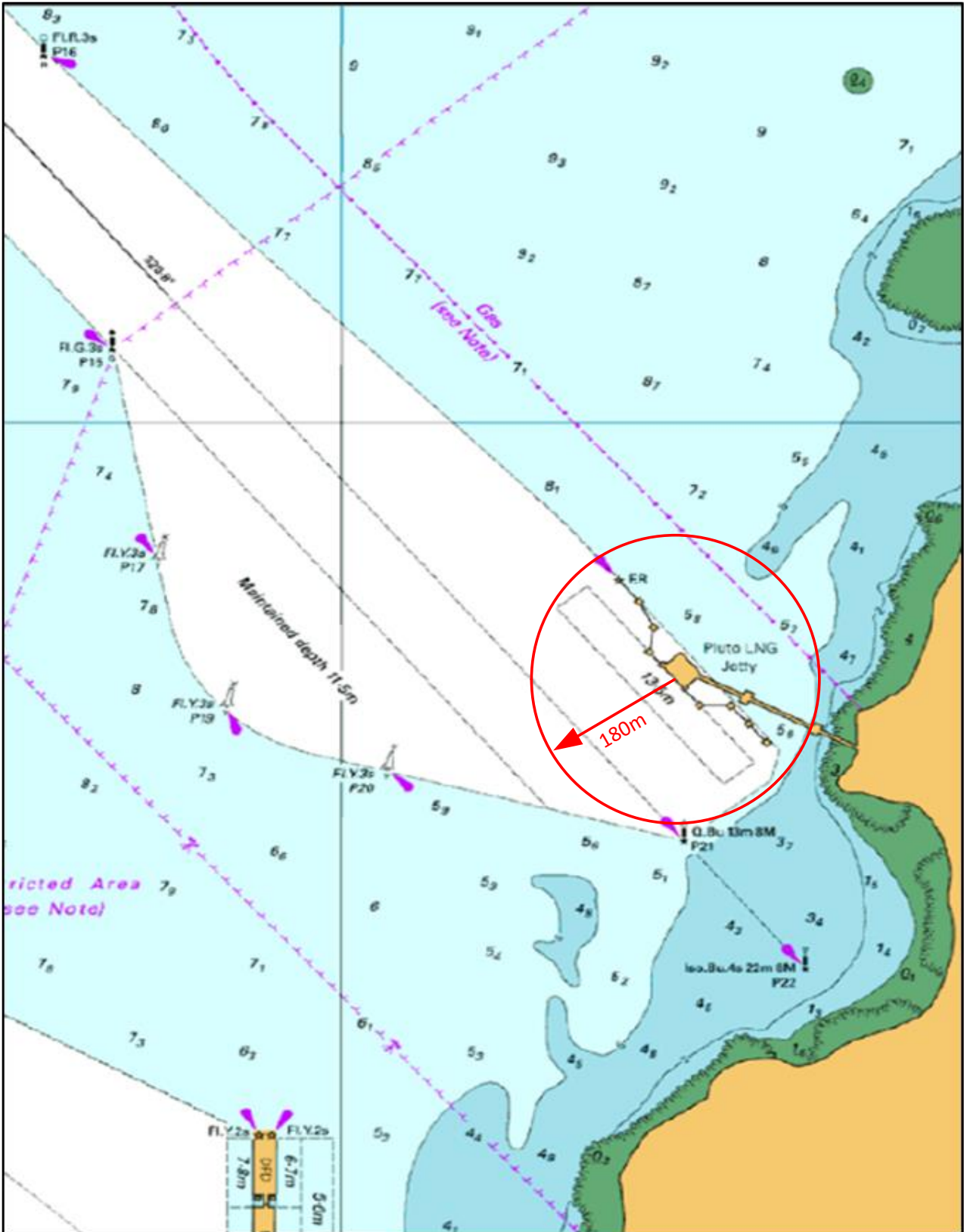

This document is protected by copyright. No part of this document may be reproduced, adapted, transmitted, or stored in any form by any process (electronic or otherwise) without the specific written consent of Woodside. All rights are reserved.

## APPENDIX C JETTY LOADING PLATFORM – GANGWAY ARRANGEMENT

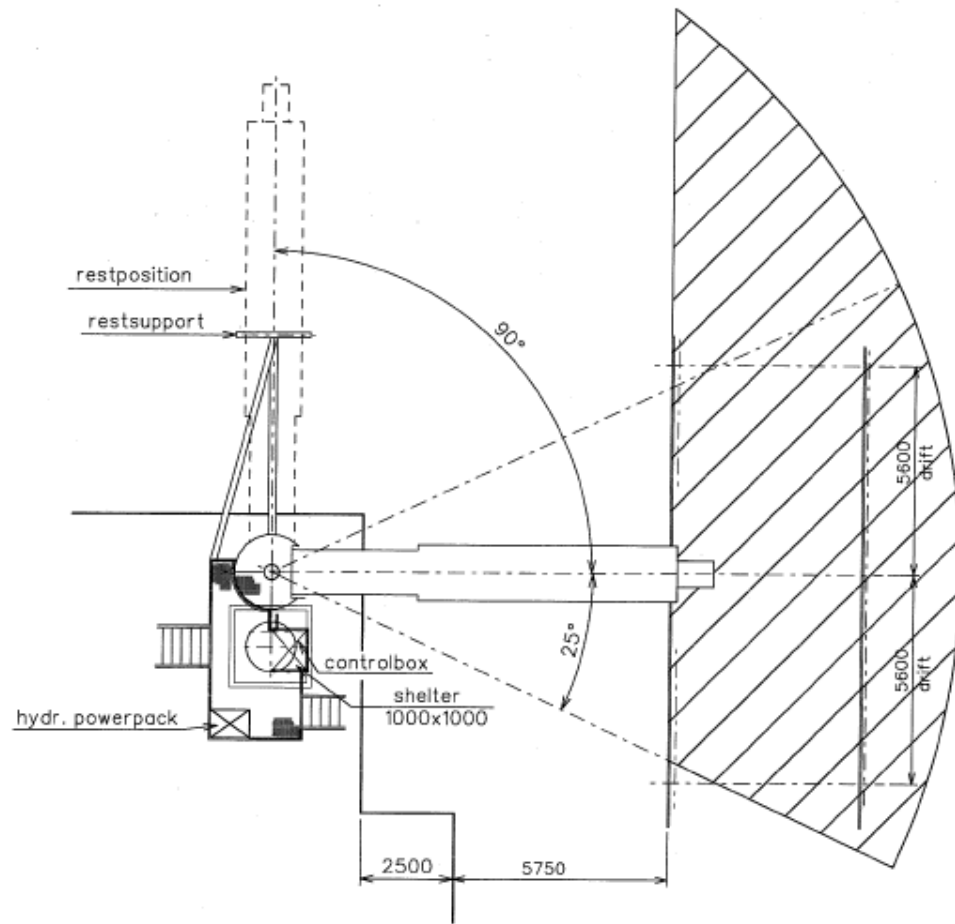

Max. Ladder range in Highest (28169 CD) and Lowest (LNG ship at 12569 CD)

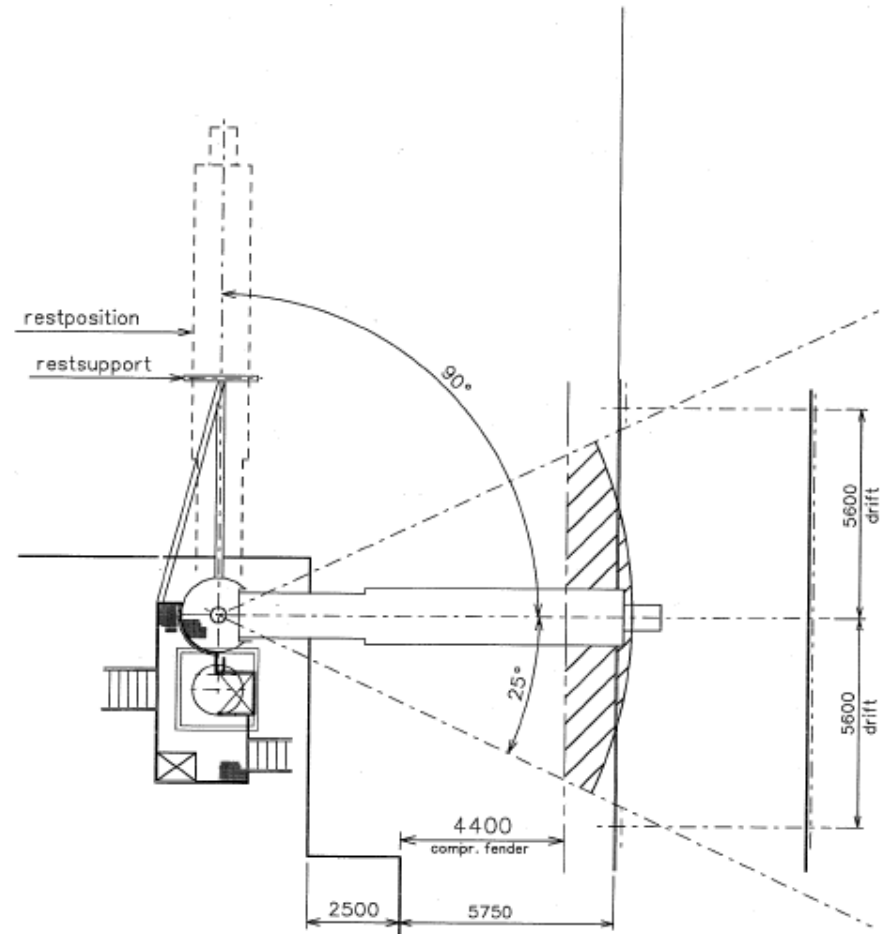

Max. Ladder range for Condensate Ship (+5569)

Smallest condensate ship (+5669),  
fullyloaded, at LLW,  
with maximum heave and roll will not  
be reached

This document is protected by copyright. No part of this document may be reproduced, adapted, transmitted, or stored in any form by any process (electronic or otherwise) without the specific written consent of Woodside. All rights are reserved.

## APPENDIX D JETTY LOADING PLATFORM – GANGWAY ARRANGEMENT (ELEVATION)

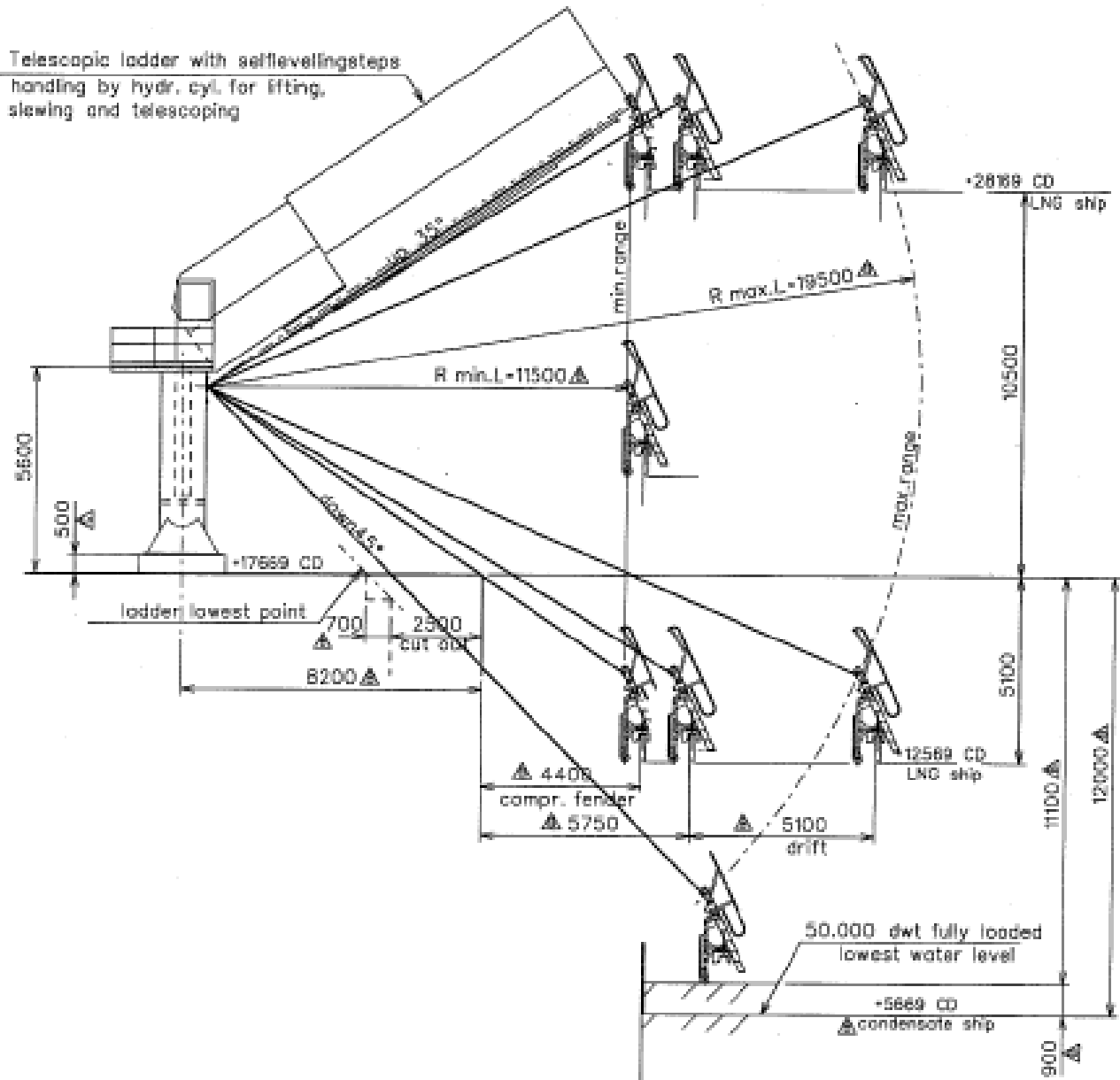

This document is protected by copyright. No part of this document may be reproduced, adapted, transmitted, or stored in any form by any process (electronic or otherwise) without the specific written consent of Woodside. All rights are reserved.

## APPENDIX E JETTY LADDER ARRANGEMENT ON GANGWAY

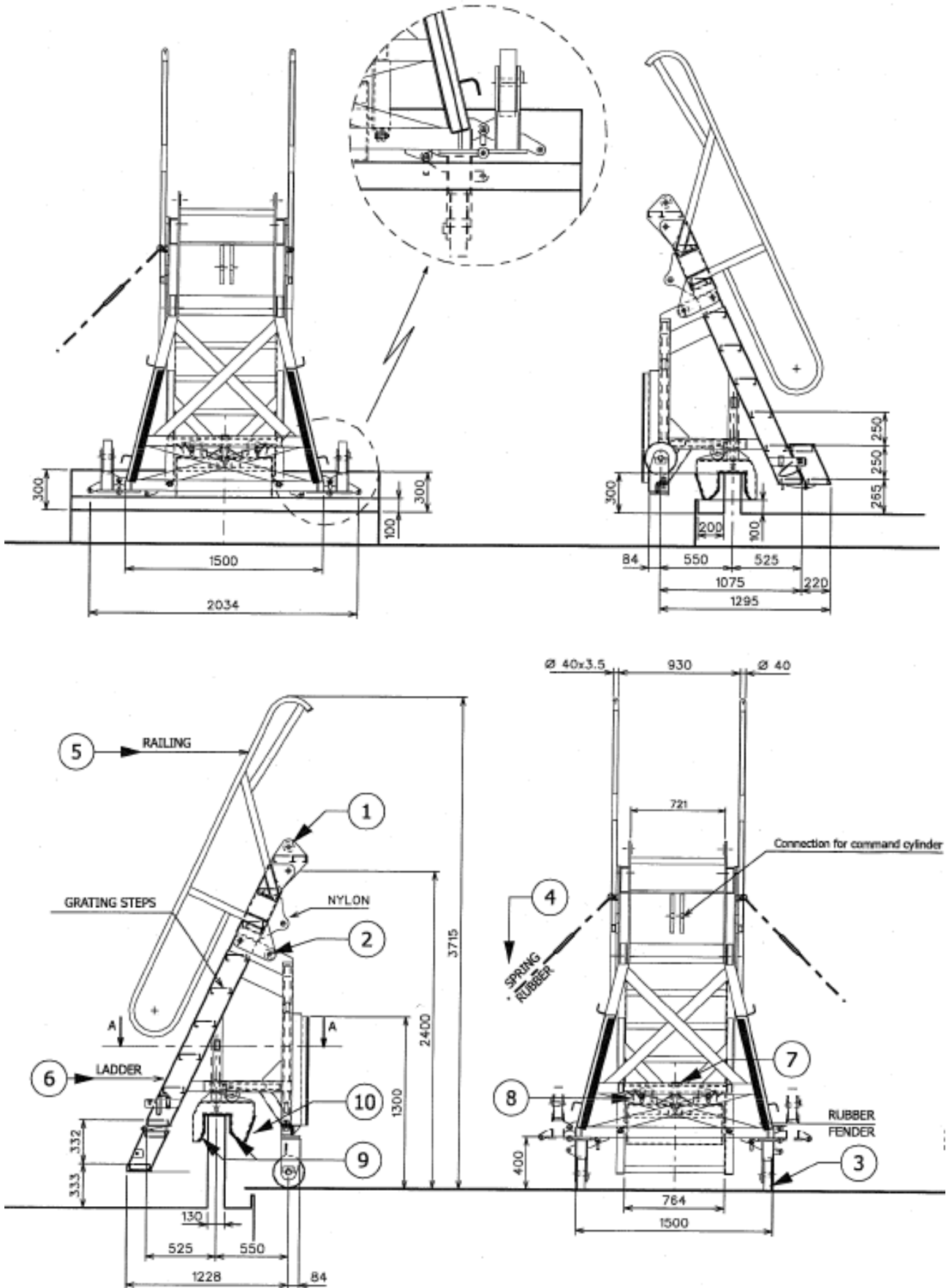

This document is protected by copyright. No part of this document may be reproduced, adapted, transmitted, or stored in any form by any process (electronic or otherwise) without the specific written consent of Woodside. All rights are reserved.



## APPENDIX G LNG LOADING ARM WORKING RANGE (PLAN)

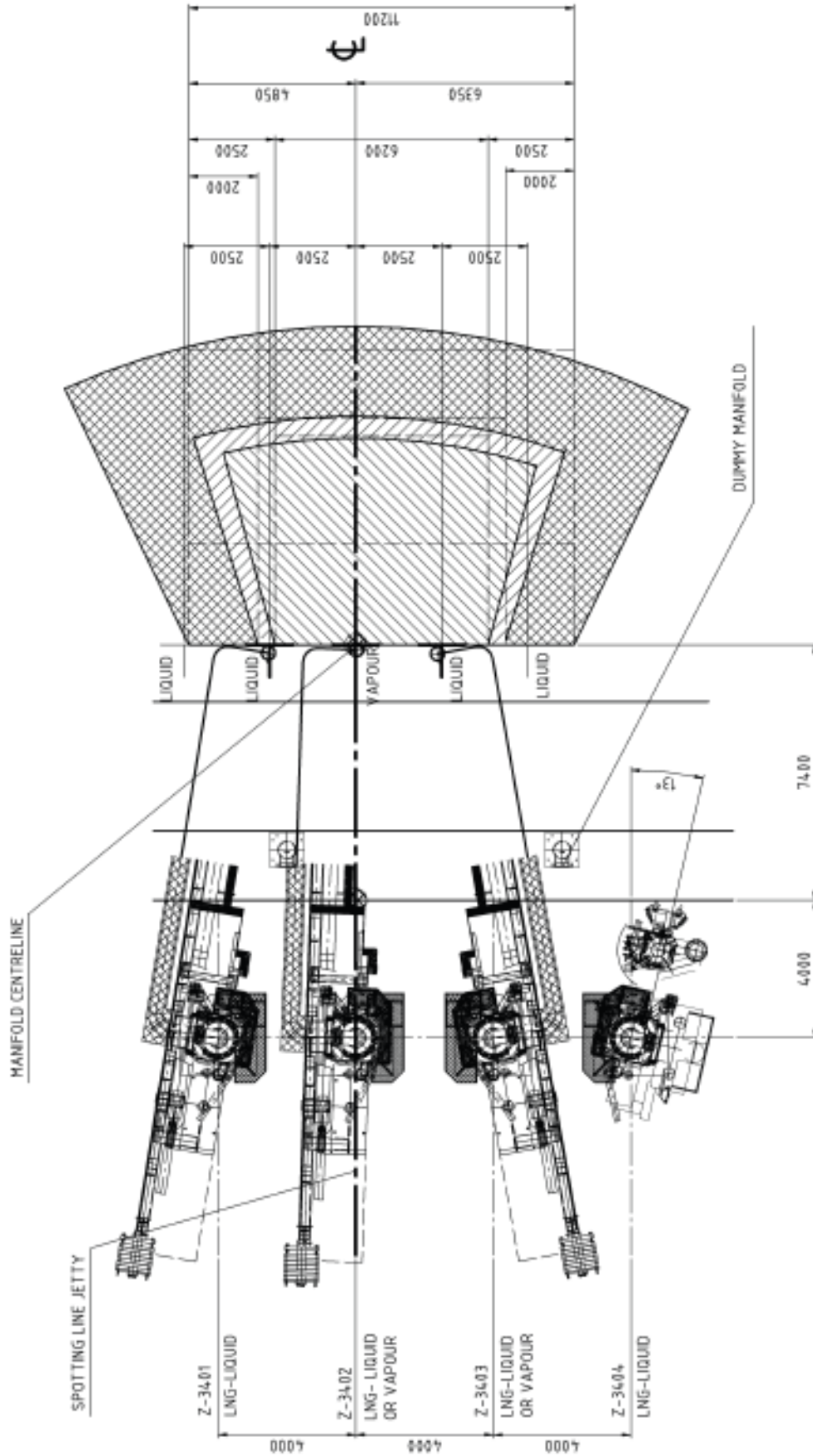

This document is protected by copyright. No part of this document may be reproduced, adapted, transmitted, or stored in any form by any process (electronic or otherwise) without the specific written consent of Woodside. All rights are reserved.





## APPENDIX J MOORING PROCEDURE

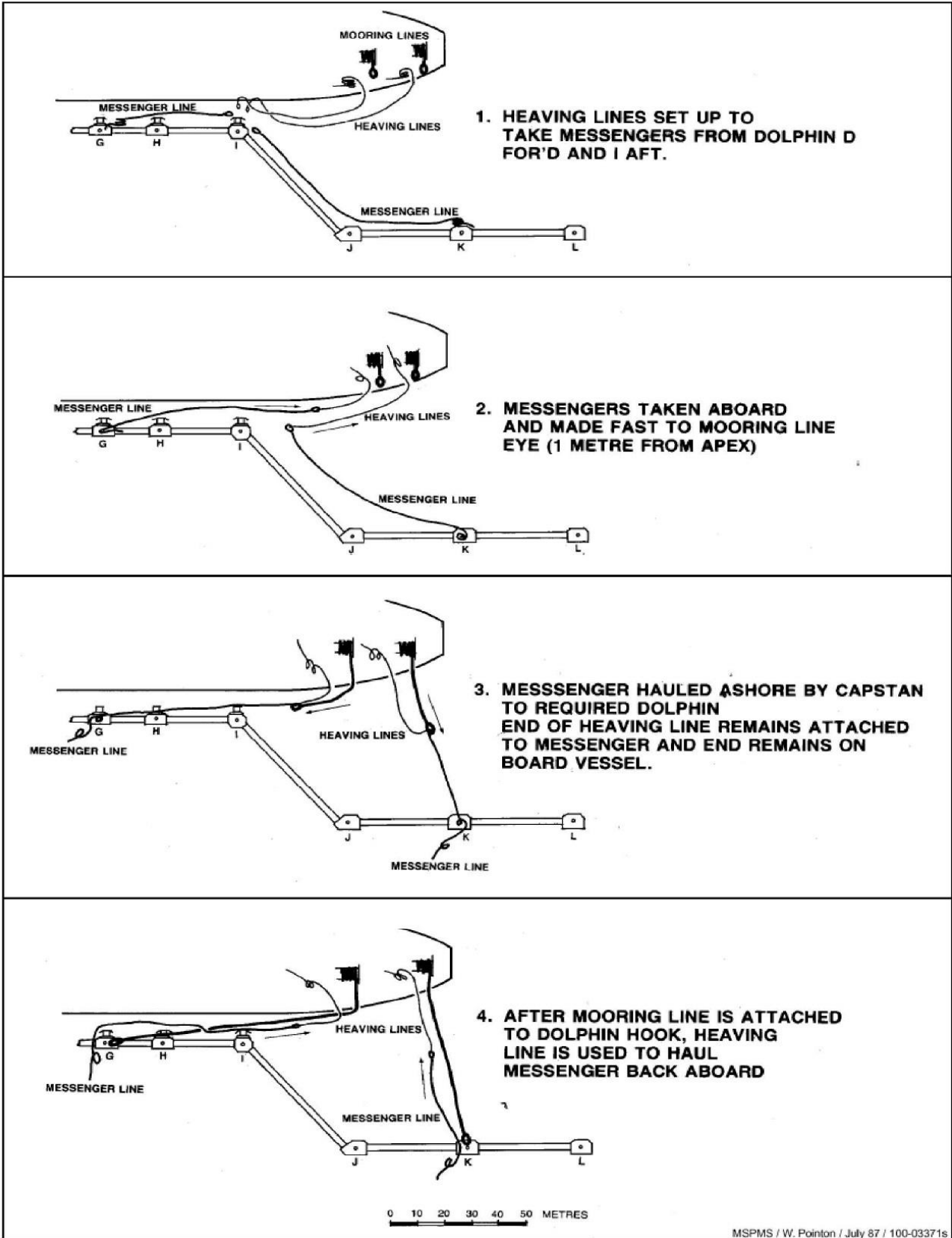

This document is protected by copyright. No part of this document may be reproduced, adapted, transmitted, or stored in any form by any process (electronic or otherwise) without the specific written consent of Woodside. All rights are reserved.

## APPENDIX K PLUTO TRANSIT AND TUG USE CRITERIA TABLE

Vessel Type	LNG		Condensate		
Vessel Size	Arrival Displacement < 115,000 t			DWT < 80K	DWT >80K
		Cargo Capacity < 170,000 m <sup>3</sup>	Cargo Capacity ≥ 170,000 m <sup>3</sup>		
Arrival	WIND LIMIT knots 10 metre/ 10-minute average	≤ 25	≤ 20	≤ 25	≤ 25
	Min Tugs	4	4	2	4
Departure	WIND LIMIT knots 10 metre/ 10-minute average	≤ 25	≤ 20	≤ 25	≤ 25
	Min Tugs	3	3	2	3
Notes	<ul style="list-style-type: none"> <li>Pilots and ship Masters are always empowered to request additional tug assistance if required.</li> <li>When planning to conduct manoeuvres in winds approaching upper limits, particularly in combination with tidal streams flowing in similar directions, consideration should be given towards ordering an additional tug for the job.</li> <li>If a 3-tug arrival for LNG or Condensate tankers is required for any reason, then limiting winds shall be determined via Operational Risk Assessment.</li> <li>Mitsubishi Sayaendo vessels (pea-pod tankers) are high windage vessels &lt;170,000 m<sup>3</sup> that are subject to a 20 kt wind limit.</li> </ul>				

This document is protected by copyright. No part of this document may be reproduced, adapted, transmitted, or stored in any form by any process (electronic or otherwise) without the specific written consent of Woodside. All rights are reserved.

## APPENDIX L PLUTO TERMINAL SPOOL PIECE (SHORT DISTANCE PIECE)

### Notes.

This adaptor piece is suitable for 16" M.I.B. Quick Connect/Disconnect Couplers at Withnell Bay Terminal. The dimensions of the adaptor and surface finish of the flange face are in accordance with the recommendations of M.I.B. International.

For correct operation and sealing, it is important that:

1. The QC/DC is fitted with tapered guides which align the coupler to the outside of the ship's flange. Therefore the diameter of the ship's flange '597' must not exceed 598.5mm (Recommended minimum diameter=595.3)
2. There must be sufficient clear space at the back of the flange to ensure freedom of movement of the hooks. The recommended minimum dimension is 90mm but in any cases this distance must not be less than 75mm. In this regard, lifting eyes should not be fitted.
3. The QC/DC is designed to connect to a flange of thickness in the range 36.6 to 39.8mm.
4. The QC/DC has two seals, a CNAF gasket for normal sealing and a PTFE energised seal which acts during transient temperature conditions such as arm cooldown. The energised seal requires a surface finish of 0.2umRa. The flange should preferably be machine as shown in way of the CNAF gasket. This machined finish may be either continuous spiral or concentric rings. Flat face flanges are also acceptable. In order to provide future re-machining allowance, a flange thickness of (say) 39mm is preferred. Bolt holes in the connection flange are optional.

Material: ASTM A182 Gr F316L.

Flanges generally follow ASME/ANSI B16.5-1988 Class 150.  
WEL Weld procedure SS2001

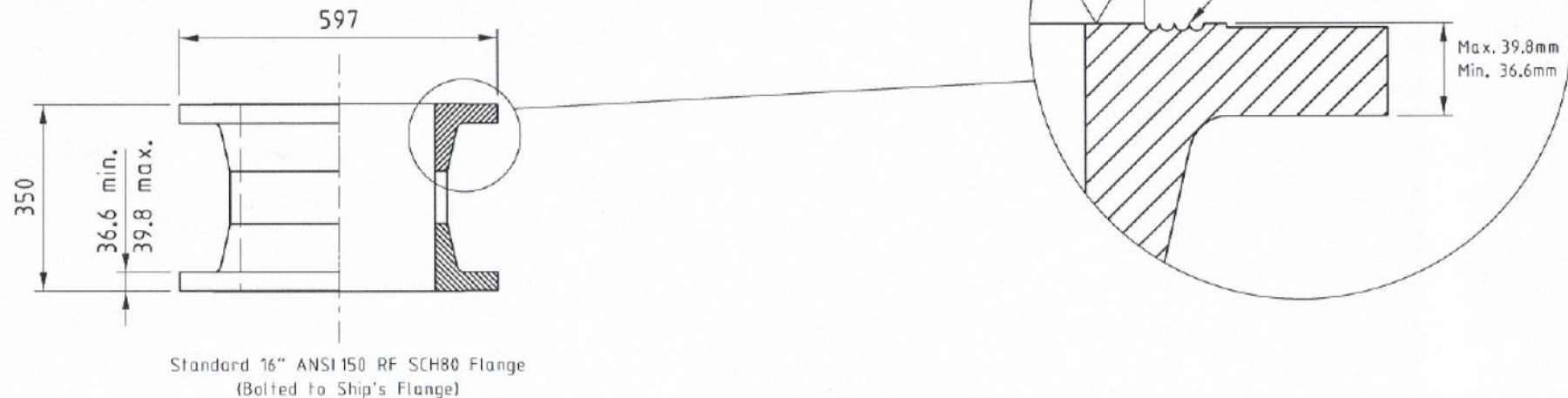

This document is protected by copyright. No part of this document may be reproduced, adapted, transmitted, or stored in any form by any process (electronic or otherwise) without the specific written consent of Woodside. All rights are reserved.

# APPENDIX M PLUTO TERMINAL JETTY

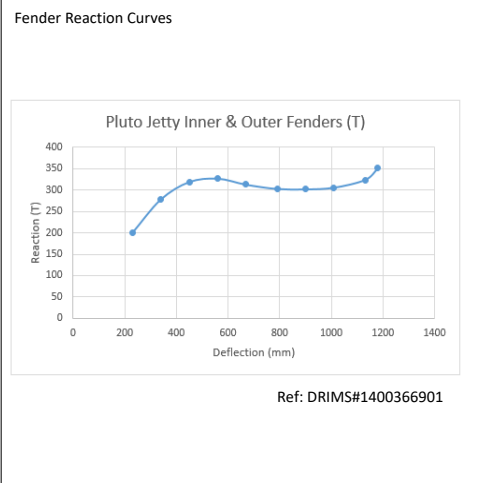
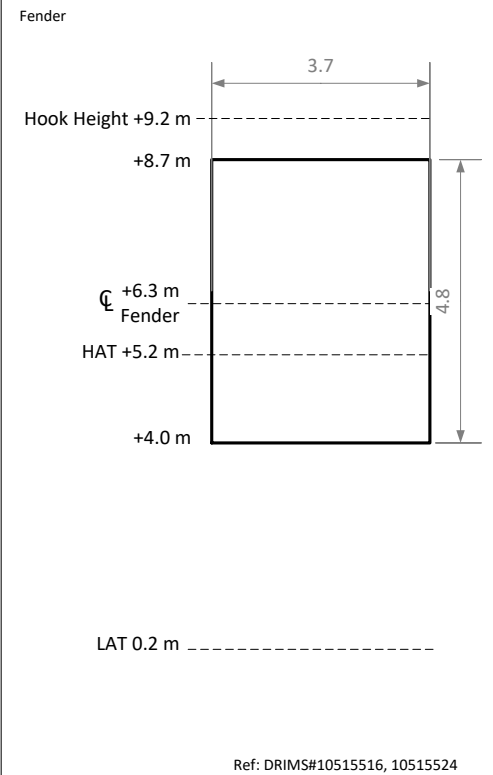
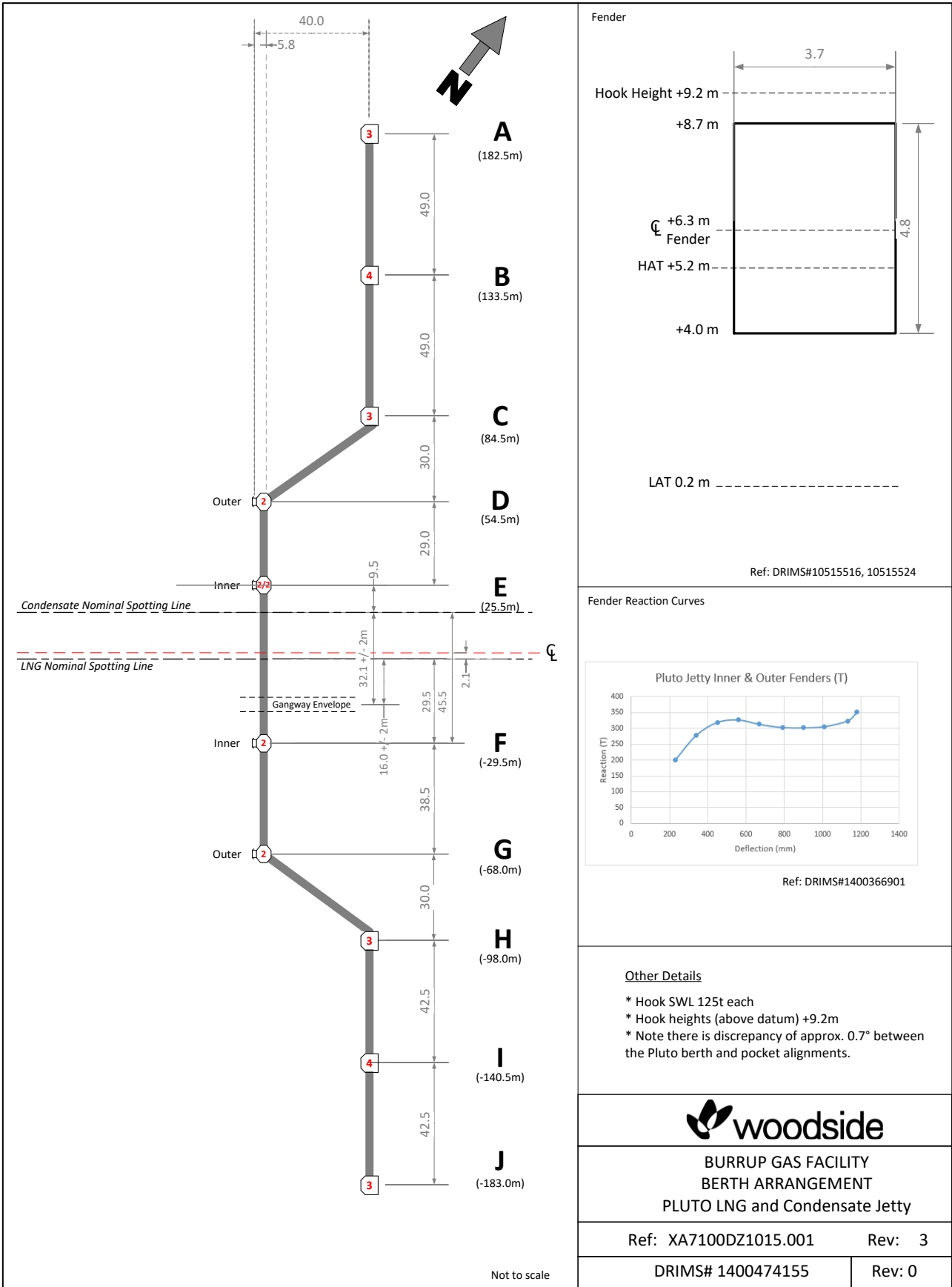

**Other Details**

- \* Hook SWL 125t each
- \* Hook heights (above datum) +9.2m
- \* Note there is discrepancy of approx. 0.7° between the Pluto berth and pocket alignments.

**woodside**

BURRUP GAS FACILITY  
BERTH ARRANGEMENT  
PLUTO LNG and Condensate Jetty

Ref: XA7100DZ1015.001      Rev: 3

DRIMS# 1400474155      Rev: 0

## APPENDIX N SECURITY ARRANGEMENTS FOR SHIP'S CREW

### Security Arrangements for Ship's Crew

#### THE MASTER:

To ensure an adequate level of security with regard to the monitoring of Ship Crews and Visitors transiting the Onshore Gas Plant, all vessels are required to implement the following procedures:

#### **Ship Crews Joining, leaving or proceeding on Shore Leave**

- Other than under exceptional circumstances, Ad Hoc requests for transportation will not be accepted after the vessel has berthed and transportation requests confirmed.
- The following information must be provided to Security at the Plant Main Gate by agent before vessels arrival:
  - Current Crew List including family members and supernumeraries.
  - Names of any crew members joining or leaving the ship at this port.
  - Names of crew members required to go ashore for medical, dental or other treatment.
  - List of visitors including name of Company and reason for visit.
  - Scheduled times for all buses servicing the ship's visit. **No movements allowed between 1600-1715 daily.**
- Crew members and visitors are required to possess photographic identification in order to be allowed access to the Onshore Gas Plant and a Woodside Pass signed by the Master or his delegate.
- When going ashore or returning to their vessel all crew members will be checked against the Crew List by security. Any personnel not registered on a crew or visitors list will not be allowed access.
- Requests for emergency transportation of crew members from the ship must be made to the Pilot/Loadmaster on board the vessel, who will liaise with Security as required.

#### **Requirements for Ship Crews Transiting Terminal**

1. No Matches or lighters are to be carried through the gas plant.
2. No mobile phones are to be taken from/to the vessel for transit through the Plant unless turned off and the battery separated from the phone. For mobile phones which cannot have their battery removed crews/visitors are to ensure these devices are switched off, locked and placed in bags provided by Security.
3. No ignition sources, namely battery powered equipment (laptops, PDA's, personal music devices, cameras, video games, torches, etc.) may be taken from / to the vessel for transit through the Plant unless the battery powered equipment is turned off and the batteries are separated from the device. For items which cannot have their battery removed such as iPods, crews/visitors are to ensure these devices are switched off and locked. Crews / visitors must declare for inspection all mobile phones and battery powered equipment to security staff while on the vessel. Equipment can then be stowed in luggage or placed in bags provided by Security.
4. Crew members are permitted to carry cigarettes through the terminal. Cigarettes must be contained in a bag and not be accessed while transiting through the site.
5. Crew members are permitted to carry alcohol through the terminal but must be declared to security prior to transiting through the site. All alcohol must be un-opened and contained in a bag.

6. Crew members and visitors proceeding ashore are to **remain on board inside the accommodation** until the terminal security escort arrives on board. Shore leavers are to remain assembled in a common area/room until the gangway watch advises that the escorting security guard has boarded the vessel. Crew members are not permitted to walk in any area of the Plant or Jetty unaccompanied by a Maritime Security Guard. Confirmation of ships drafts from the mooring dolphins are the only permitted exception to above rule and require terminal representative approval.  
PLEASE ENSURE SHORE LEAVERS DO NOT DISEMBARK THE VESSEL UNTIL A SECURITY GUARD ARRIVES AT THE GANGWAY TO ESCORT THEM TO THEIR TRANSPORT. SHORE LEAVERS TO REMAIN ASSEMBLED IN THE ACCOMMODATION UNTIL THE MARITIME SECURITY ESCORT ARRIVES ON BOARD.
7. Children under 15 years of age require special approval from Terminal Management to transit the terminal (notification is required minimum 72 hours prior to arrival. Approval is at Terminal Management’s discretion and will not be honoured during high risk or maintenance periods.
8. Crew members and visitors to wear correct PPE (enclosed footwear, long trousers, long sleeved shirt, glasses and helmet. PPE may be left with Security at main gate and reclaimed before returning to ship.) Children are to have an equivalent level of PPE dependent on their age and ability to wear PPE.
9. All crews transiting the facility must adhere to West Australian road rules.
10. Ship’s crew members may be subject to random drug and alcohol testing in conformity with the Onshore Gas Plant’s Drug and Alcohol policy, Ship’s crew are permitted a BAC reading no higher than 0.04.

**Third Party Personnel visiting vessels**

The names of all visitors to the ship, together with their company and the reason for the visit, must be provided to the Shipping Office for approval via the Agents. Personnel not registered as visitors will not be allowed access to the Jetty.

**In the event of any infringement of these regulations, Woodside Energy Ltd reserves the right to prohibit shore access to ship crew members.**

Signed	Accepted:
Pilot/Loadmaster	Master
Name: .....	Name: .....

# APPENDIX O REQUIRED BOARDING ARRANGEMENTS FOR PILOT

## REQUIRED BOARDING ARRANGEMENTS FOR PILOT

In accordance with SOLAS Regulation V/23 & IMO Resolution A.1045(27)

**INTERNATIONAL MARITIME PILOTS' ASSOCIATION**

H.Q.S. "Wellington" Temple Stairs, Victoria Embankment, London WC2R 2PN Tel: +44 (0)20 7240 3973 Fax: +44 (0)20 7210 3518 Email: office@impahq.org

This document and all IMO Pilot-related documents are available for download at: <http://www.impahq.org>

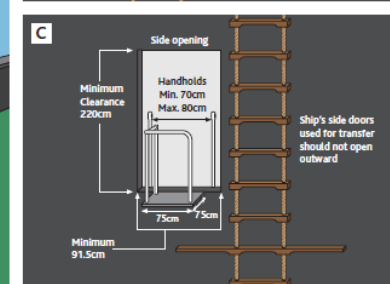
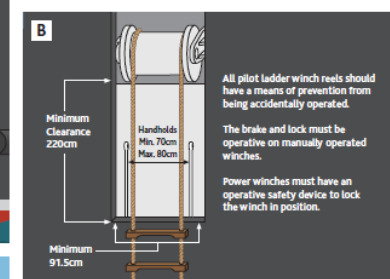
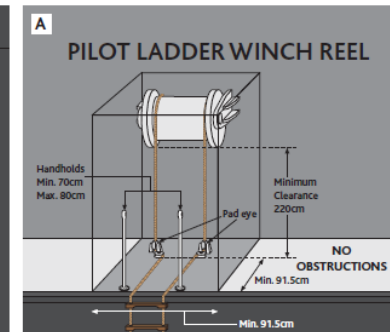
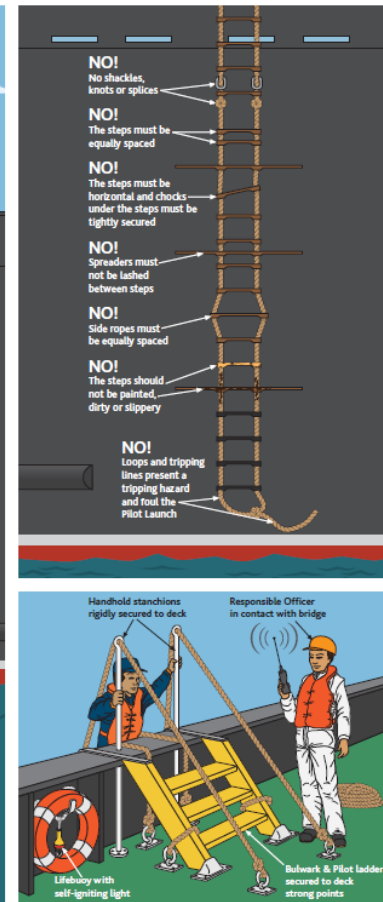
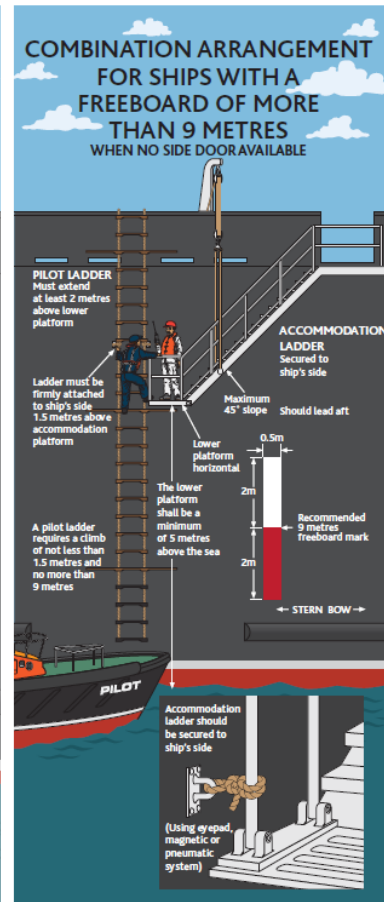
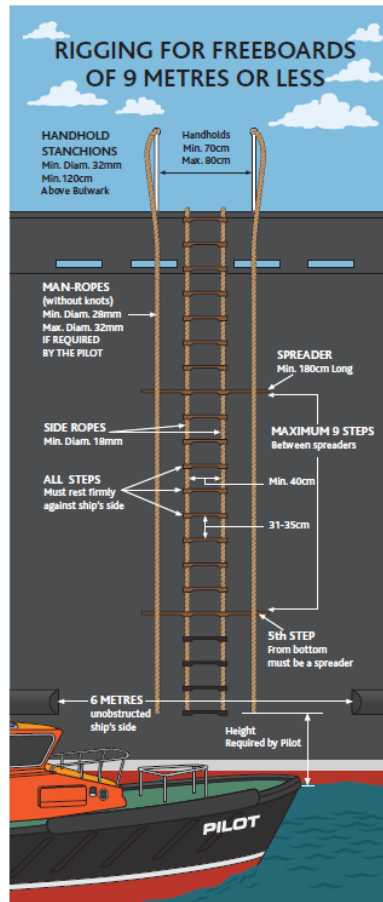

This document is protected by copyright. No part of this document may be reproduced, adapted, transmitted, or stored in any form by any process (electronic or otherwise) without the specific written consent of Woodside. All rights are reserved.

## APPENDIX P PLUTO TERMINAL PRE-ARRIVAL QUESTIONNAIRE (LNG TANKER)

Pre-Arrival Questionnaire for LNG Tankers					
Due 3 Days Prior to Arrival					
<b>Vessel</b>					
Date:					
Vessel Name:					
Masters Name:					
Port of Registry:					
<b>Pilot Ladder</b>					
1	Date of Manufacture:	Port Ladder		Stbd Ladder	
2	Are there any replacement steps?	Please Select		How many?	
3	Are there any replacement spreaders?	Please Select		How many?	
4	Date of last inspection (other than visual):				
<b>Arrival</b>					
5	Estimated Date/Time of Arrival:				
6	Estimated Arrival Drafts:	Fwd:	m	Aft:	m
7	Arrival Displacement:		tonne		
8	Estimated Tank Temperatures on Arrival:		°C		
9	Cooldown Period Required?		hrs		
<b>Departure</b>					
10	Estimated Departure Drafts?	Fwd:	m	Aft:	m
11	Estimated Departure Displacement?		tonne		
12	Main engine warm through time required prior to departure from berth?		hrs		
<b>Please confirm the following:</b>					
13	Are the crew all healthy with no reported COVID symptoms?				Please Select
14	All Navigation, Mooring, Safety and Engine Systems are fully operational?				Please Select
15	Main Engine/s can attain the posted manoeuvring RPM's without additional delay? (For example: EEX/EEED Engine Power Limitations for manoeuvring RPM's can be overridden for				Please Select
16	No Tank Leakage?				Please Select
17	The following systems are operating correctly and have been inspected / tested?				
	a	Cargo system and boil off control equipment?			Please Select
	b	Gas Detection Analysers?			Please Select
	c	ESDS, alarms and interlocks?			Please Select
	d	Tank high level alarms?			Please Select
	e	Tank low / high pressure alarms?			Please Select
	f	Remote operated valves			Please Select
	g	ESD valves pressure tested and confirmed tight?			Please Select
18	Does the vessel have a vapour strainer fitted?				Please Select
19	Cargo tanks and lines free of oxygen?				Please Select
20	Stress calculations for cargo, ballast and bunker transfers made within recommended safety limits?				Please Select
21	Vessel has a valid International Ships Security Certificate?				Please Select
22	The current (MARSEC) Security Level under which the vessel is operating?				Please Select
23	Did the vessels previous port have a valid Maritime Security Plan?				Please Select
24	Are the vessel's mooring lines fitted with Jockey Ropes?				Please Select
25	If so, what is the overall condition of the Jockey Ropes?				Please Select
26	When were the Jockey Ropes last changed?				
27	Ballast Water:				
	a.	Ballast quantity, type (SBT, CBT, DIRTY), origin?			
	b.	Has the vessel complied with Biosecurity Act 2015 for Ballast Water Management?			Please Select
	c.	If Ballast Water Treatment System (BWTS) is used, has the operator shared the BWTS certificate with Woodside Marine Assurance?			Please Select
	d.	If ballast water exchange is used, has the vessel complied with Department of Agriculture Ballast Water Management Requirements for exchange of ballast water?			Please Select
<b>Mooring Lines and Tails</b>					
28	Vessels replacement policy of mooring line/wires and tails.			her/another/other.	
29	Does your vessel carry 22m tails to fit to all mooring lines except forward and aft spring lines that are fit				Please Select
<p><i>Withnell Bay (KGP) Terminal Handbook 8.7: For the date range, 1st May to 1st November, all LNG carriers are strongly recommended to fit 22 metre mooring tails for all lines except forward and aft backsprings. Should an LNG carrier not be able to fit 22 metre mooring tails, Woodside Port Operations must be notified as soon as possible. Outside of this date range, 22 metre tails may be requested by Port Operations or can be fitted at the ship's discretion in lieu of 11 metre mooring tails.</i></p>					
<b>Please fill out the attached worksheet with the below information regarding mooring lin</b>					
30	Age of each mooring line/wire and tails.				
31	Last date of inspection of mooring lines/wires and tails.				
32	Visual condition of each mooring line/wire and tail.				
For your information the pilot will discuss mooring arrangements with the vessel prior to berthing.					
Please have your mooring line certificate and inspection reports ready for inspection by a Terminal Representative.					
					Rev 11 27/04/2025

This document is protected by copyright. No part of this document may be reproduced, adapted, transmitted, or stored in any form by any process (electronic or otherwise) without the specific written consent of Woodside. All rights are reserved.

## APPENDIX Q PLUTO TERMINAL PRE-ARRIVAL QUESTIONNAIRE (CONDENSATE TANKER)

Pre-Arrival Questionnaire for Oil Tankers										
Due 3 Days Prior to Arrival										
<b>Vessel</b>										
Date:										
Vessel Name:										
Masters Name:										
Port Of Registry:										
<b>Pilot Ladder</b>										
1	Date of Manufacture:	Port Ladder					Stbd Ladder			
2	Are there any replacement steps?	Please Select				How many?	N/A			
3	Are there any replacement spreaders?	Please Select				How many?	N/A			
4	Date of last inspection (other than visual):									
<b>Arrival</b>										
5	Estimated Date/Time of Arrival:									
6	Estimated Arrival Drafts:	Fwd:				m	Aft:			
7	Estimated Arrival Displacement:					tonne				
<b>Departure</b>										
8	Estimated Departure Drafts?	Fwd:				m	Aft:			
9	Estimated Departure Displacement?					tonne				
<b>Please confirm the following:</b>										
10	All Navigation, Mooring, Safety and Engine Systems are fully operational:					Please Select				
11	All cargo systems leak free and fully operational?					Please Select				
12	Inert gas system operational, tanks inerted to less than 8% O2.									
13	Any residue traces of H2S will be less than 5 ppm on arrival at terminal?					Please Select				
14	All cargo systems, transfer equipment inspected. Leak free and operating correctly?					Please Select				
15	Stress calculations for cargo, ballasting, bunkering transfers made and within recommended safety limits.					Please Select				
16	The maximum loading rate for the present loading operation?					cu m/hr				
17	Maximum loading rate through one port 16" manifolds?					cu m/hr				
18	Maximum loading rate through two starboard 16" manifolds?					cu m/hr				
19	Does manifold arrangement comply with OCIMF standards.					Please Select				
20	Ballast Water:									
	a.	Ballast quantity, type (SBT, CBT, DIRTY), origin?								
	b.	Has the vessel complied with Biosecurity Act 2015 for Ballast Water Management?					YES			
	c.	If Ballast Water Treatment System (BWTS) is used, has the operator shared the BWTS certificate with Woodside Marine Assurance?					YES			
	d.	If ballast water exchange is used, has the vessel complied with Department of Agriculture Ballast Water Management Requirements for exchange of ballast water?					N/A			
21	Vessel has a valid International Ships Security Certificate?					YES				
22	The current (MARSEC) Security Level under which the vessel is operating?					Security Level 1				
23	Did the vessel's previous port have a valid Maritime Security Plan?					Please Select				
<b>Mooring Lines and Tails</b>										
24	Vessels replacement policy of mooring line/wires and tails.									
		Mooring lines:					hrs / months / or other.			
		Tails:					hrs / months / or other.			
<i>For inshore terminals please fill out the attached Mooring Line &amp; Tail Data worksheet with information regarding mooring lines/wires and tails.</i>										
<i>For your information the pilot will discuss mooring arrangements with the vessel prior to berthing.</i>										
<i>Please have your mooring line certificates and inspection reports ready for inspection by a Terminal Representative.</i>										

**Note:** There are no shore reception facilities for dirty ballast or slops.

This document is protected by copyright. No part of this document may be reproduced, adapted, transmitted, or stored in any form by any process (electronic or otherwise) without the specific written consent of Woodside. All rights are reserved.

## APPENDIX R SANCTIONS ASSESSMENT PROCEDURE

### Sanctions Assessment Procedure

For Vessels Visiting Woodside Terminals

1. The Vessel Owners (and Vessel Personnel) are bound under:
  - a. clause 3 (Conditions of Use) of the Withnell Bay Jetty Terminal Conditions; or
  - b. clause 3 (Conditions of Use) of the Pluto Terminal Conditions,  
as applicable (the 'Terminal Conditions').
2. This Sanctions Assessment Procedure ('Procedure') forms part of the 'Terminal Handbook' applicable at the Terminal and is issued under the Terminal Conditions. Any defined terms in the Terminal Conditions carry the same meaning within this Procedure unless defined otherwise in this Procedure.
3. The Company undertakes Sanctions assessments prior to the provision of Jetty Services to Vessel Owners. As a result of these Sanctions assessments or otherwise, the Company may require a declaration to be submitted (refer to the following page) ('Declaration') prior to the relevant loading date at the Woodside terminal. The Company will give prior notice in writing of this to any Vessel Owner if required by the Company.
4. Should there be any change of circumstances that would affect the responses after submission of the Declaration (if required by the Company), immediate re-submission is required with updated information.
5. The Company may undertake ongoing Sanctions assessments and is not bound by a response in any Declaration submitted to the Company.
6. The Company may withhold, suspend or terminate the provision of Jetty Services and require the removal of any Vessel from the Jetty, or take any other action the Company reasonably considers appropriate (and the Terminal Representative may give directions accordingly), taking into account the responses in the Declaration (or any re-submitted Declaration) or the Company's own and ongoing Sanctions assessments.

**WHERE REQUIRED, COMPLETED DECLARATIONS (REFER TO FOLLOWING PAGE) AND UPDATED INFORMATION TO BE SENT TO [PilotLoadingMaster@woodside.com.au](mailto:PilotLoadingMaster@woodside.com.au)**

NOTE: Completion of the Declaration is a Company requirement in the circumstances described above.

#### Definitions

'Sanctions' means any trade, political, economic or financial sanctions laws, regulations, embargoes, or restrictive measures administered, enacted or enforced by any Sanctioning Authority.

'Sanctioning Authority' means any government and their relevant emanations and official institutions including those of: Australia, New Zealand, the USA, the United Nations Security Council; the European Union (and each of its member states), the United Kingdom, Switzerland and Japan.

'Sanctions List' means the Consolidated List maintained by the Australian Government Department of Foreign Affairs and Trade, or any list maintained by, or public announcement of a Sanctions designation made by, a Sanctioning Authority from time to time.

'Restricted Party' means any person or entity listed on a Sanctions List or any person or entity organised, located or resident in a country or territory that is, or whose government is, the target of Sanctions.

This document is protected by copyright. No part of this document may be reproduced, adapted, transmitted, or stored in any form by any process (electronic or otherwise) without the specific written consent of Woodside. All rights are reserved.

## Sanctions Declaration

<b>Date completing form:</b>	Click here to enter a date	<b>Woodside Load Port Terminal:</b>	Click here to enter text
<b>Vessel Name:</b>	Click here to enter text	<b>Agent(s):</b>	Click here to enter text
<b>Master's Name:</b>	Click here to enter text	<b>Load Date:</b>	Click here to enter text

Questions answered "Yes" require detailed comments in remarks section below		
1.	Is the Vessel Owner or any Vessel Personnel a Restricted Party?	<input type="checkbox"/> Yes <input type="checkbox"/> No
2.	Is the Vessel Owner or any Vessel Personnel directly or indirectly owned or controlled by a Restricted Party?	<input type="checkbox"/> Yes <input type="checkbox"/> No
3.	Is the Vessel Owner or any Vessel Personnel engaging in or has engaged in any transaction or conduct that could result in it becoming a Restricted Party?	<input type="checkbox"/> Yes <input type="checkbox"/> No
4.	Is or has the Vessel Owner or any Vessel Personnel been subject to any allegation, claim, proceeding, formal notice or investigation with respect to any Sanctions?	<input type="checkbox"/> Yes <input type="checkbox"/> No
5.	Is the Vessel Owner or any Vessel Personnel engaging in, or has engaged in, directly or indirectly, any transaction or conduct which evades or avoids, or has the purpose of evading or avoiding, or breaches or attempts to breach any Sanctions applicable to it?	<input type="checkbox"/> Yes <input type="checkbox"/> No
6.	Has the Vessel Owner or any Vessel Personnel engaged in, or is engaging in, directly or indirectly, any trade, business or other activity with or for the benefit of any Restricted Party?	<input type="checkbox"/> Yes <input type="checkbox"/> No

Question Number	Remarks for questions answered "Yes"

Master's Name: \_\_\_\_\_

Signature: \_\_\_\_\_

Date: \_\_\_\_\_

Ship STAMP:

(Source: [SharePoint](#))